

# Axiomatic Theories of the Ontology of Time in GFO

Ringo Baumann<sup>a</sup>, Frank Loebe<sup>a,\*</sup>, and Heinrich Herre<sup>b,\*\*</sup>

<sup>a</sup> *Department of Computer Science, University of Leipzig, Germany*

<sup>b</sup> *Institute of Medical Informatics, Statistics and Epidemiology (IMISE), University of Leipzig, Germany*

**Abstract.** Time is a pervasive notion of high impact in information systems and computer science altogether. Respective understandings of the domain of time are fundamental for numerous areas, frequently in combination with closely related entities such as events, changes, and processes. The conception and representation of time entities and reasoning about temporal data and knowledge are thus significant research areas. Each representation of temporal knowledge bears ontological commitments concerning time. Thus it is important to base temporal representations on a foundational ontology that covers general categories of time entities.

In this article we introduce and discuss two consecutive ontologies of time that have been developed for the top-level ontology General Formal Ontology (GFO). The first covers intervals, named *chronoids*, and *time boundaries* of chronoids as a kind of time points. One important specialty of time boundaries is their ability to *coincide* with other time boundaries. The second theory extends the first one by additionally addressing *time regions*, i.e., mereological sums of chronoids.

Both ontologies are partially inspired by ideas of Franz Brentano, especially from his writings about the continuum. In particular, we view continuous time intervals as a genuine phenomenon which should not be identified with intervals (sets) of real numbers. On these grounds the resulting ontologies allow for proposing novel contributions to several problematic issues in temporal representation and reasoning, among others, the Dividing Instant Problem and the problem of persistence and change.

Following our general approach to ontology development, both ontologies are axiomatized as formal theories in first-order logic and are analyzed metalogically. We prove the consistency of both ontologies, and completeness and decidability for one. Moreover, standard time theories with points and intervals are covered by both theories.

Keywords: Ontology of Time, Time Point, Time Interval, Coincidence, Brentano

## Introduction<sup>1</sup>

Space and time are basic categories of any top-level ontology. They are fundamental assumptions for the mode of existence of those individuals that are said to be in space and time. In this paper we expound the ontology of time which is adopted by the General Formal Ontology (GFO) (Herre, 2010), a top-level ontology being developed by the research group Ontologies in Medicine and Life Sciences<sup>2</sup> (Onto-Med) at the University of Leipzig. The time ontology together with the space ontology of GFO (Baumann & Herre, 2011) forms the basis for an ontology of material individuals.

There is an ongoing debate about whether time is ideal and subject-dependent or whether it is a real entity being independent of the mind. We defend the thesis that time exhibits two aspects. On the one hand, humans perceive time in relation to material entities through phenomena of duration, persistence, happening, non-simultaneity, order, past, present and future, change and the passage of time. We adopt the position that these phenomena are mind-dependent. On the other hand, we assume that material entities possess mind-independent dispositions to generate these temporal phenomena. We call these dispositions

---

\*Corresponding author. Frank Loebe, Department of Computer Science, University of Leipzig, Augustusplatz 10, 04109 Leipzig, Germany. Tel.: +49 341 9732236; Fax: +49 341 9732299  
E-Mail: frank.loebe@informatik.uni-leipzig.de

\*\*Corresponding author. Heinrich Herre, Institute of Medical Informatics, Statistics and Epidemiology, University of Leipzig, Haertelstrasse 16-18, 04107 Leipzig, Germany. Tel.: +49 341 9716161; Fax: +49 341 9716109  
E-Mail: heinrich.herre@imise.uni-leipzig.de

<sup>1</sup>This paper is a substantially extended and revised version of “Ontology of Time in GFO” by the same authors in the Proceedings of the 7th International Conference on Formal Ontology in Information Systems (FOIS 2012).

<sup>2</sup><http://www.onto-med.de>

*temporality* and claim that they unfold in the mind/subject as a manifold of temporal phenomena. This distinction between the temporality of material entities and the temporal phenomena (called *phenomenal time*) corresponds to the distinction between temporality and time as considered by Nicolai Hartmann (1935–1950). A satisfactory ontology of time and its formal representation should treat the various temporal phenomena in a uniform and consistent manner. We suggest to address the following basic tasks.

1. The development of an ontology of time itself, abstracted from real phenomena. We call this time *abstract phenomenal time*.
2. The development of an ontology, describing precisely how material entities (objects, processes) are related to abstract phenomenal time and how temporal phenomena are represented.
3. The establishment of a truth-relation between temporal propositions and spatio-temporal reality, also termed the problem of *temporal incidence* (Vila, 2005).
4. The elaboration of a unifying formal axiomatization of the ontology of time and of material entities of the spatio-temporal reality, the *formalization problem*.

The present paper is a contribution to solving these problems. While our results mainly pertain to the first and fourth issues, the second and third provide corresponding motivations and application cases.

This work proposes and analyzes two ontologies of time as axiomatic theories, aiming at a solid foundation for several applications. Among the latter are truth assignments to temporal propositions and a capable and consistent solution to the Dividing Instant Problem (DIP) (cf. Allen, 1983). The first theory of abstract phenomenal time, labelled  $\mathcal{BT}^C$ , focuses on time intervals, perceived as genuine entities from an ontological point of view. To avoid confusion with accounts of time that are based on intervals (sets) of real numbers (and may even identify these with time intervals), we refer to such genuine intervals as *chronoids*. A clear distinction between the mathematical rendering of continuous phenomena, e.g. in terms of the real numbers, and the actual phenomena themselves is an important inspiration to this work, primarily following corresponding criticism purported by Franz Brentano (1976). Chronoids have two extremal *time boundaries*, which is the second kind of entities in the domain of  $\mathcal{BT}^C$ . No time boundary can exist without a chronoid that it is the boundary of, hence they are existentially dependent on chronoids. Roughly speaking, time boundaries may be called and seen as time points. Yet there is an uncommon but powerful feature of time boundaries, expounded in section 4.1, that is their ability to *coincide*. The “existential priority” of chronoids over time boundaries and the notion of coincidence constitute major differences to usual dual time theories of points and intervals, such as  $\mathcal{IP}$  (Vila, 1994, 2005, sect. 1.7.2).<sup>3</sup> The second theory developed,  $\mathcal{BT}^R$ , addresses chronoids, time boundaries, and in addition mereological sums of the entities of each kind, called *time regions* and *time boundary regions*, respectively. Due to technical reasons,  $\mathcal{BT}^C$  is not literally a subtheory of  $\mathcal{BT}^R$ , but there is a natural interpretation into  $\mathcal{BT}^R$ . Initial metalogical analysis completes the introduction of each ontology, in particular establishing the consistency of the axiomatizations.

The paper is organized as follows. First, we outline the Onto-Axiomatic Method, i.e., general principles underlying our approach of ontological analysis and the development of formal axiomatizations of a domain, in section 1, which further includes some formal preliminaries. In section 2 we present a focused state of the art on time, concentrating on axiomatic theories in temporal representation and reasoning and summarizing how other top-level ontologies deal with time. Section 3 introduces selected problems of temporal qualification and incidence and proposes desiderata for an ontology of abstract phenomenal time. An informal introduction to time in GFO and to related kinds of entities in section 4 allows us in section 5 to illustrate new approaches to the problems previously introduced. Section 6 introduces  $\mathcal{BT}^C$ , the first axiomatization of abstract phenomenal time for GFO in first-order logic (FOL), which focuses on chronoids (time intervals) and time boundaries (time points). This is accompanied by investigating the metalogical properties of the theory  $\mathcal{BT}^C$  in section 7. Thereafter, sections 8–10 follow the same structure of conceptual outline, axiomatization, and metalogical analysis to present the extended theory  $\mathcal{BT}^R$ . Section 11 completes this part by briefly discussing temporal abstraction as a problem for which time regions

<sup>3</sup> $\mathcal{IP}$  is contained in section 7.3, where an interpretation into  $\mathcal{BT}^C$  is shown.

are directly relevant. In section 12 we summarize our results, draw some conclusions and outline several problems and tasks for future research.

## 1. Principles of the Onto-Axiomatic Method

A few methodological and technical clarifications are beneficial before we focus on the specific domain of time. The understanding of *Formal Ontology* as presupposed in this paper has its roots in formal logic, philosophical ontology, and artificial intelligence. Formal Ontology is an evolving science which aims at the development of formal theories describing forms, modes, and views of being of the world at different levels of abstraction and granularity (cf. also Cocchiarella, 1991). An essential characteristic of formal ontology is the *axiomatic method* which comprises principles for the development of theories, aiming at the foundation, systematization, and formalization of a field of knowledge about a domain of the world. If knowledge of a domain is assembled in a systematic way, a set of categories is stipulated as primitive or basic. Primitive categories are not defined by explicit definitions, but by axioms that define their meaning implicitly (Hilbert, 1918).

The considered axioms exhibit various degrees of generality. At the most general level of abstraction these theories are called top-level ontologies, the axioms and categories of which can be applied to most domains of the world. The *onto-axiomatic method* combines the axiomatic method with the inclusion of a top-level ontology which is used to establish more specialized ontologies which can be classified into *core ontologies* and *domain specific ontologies*.

Top-level ontologies are intended to play an analogous role for the world in general as set theory for mathematics<sup>4</sup>. GFO adopts set theory, in contrast to other top-level ontologies such as the Basic Formal Ontology (BFO) (Grenon, Smith, & Goldberg, 2004) and the Descriptive Ontology for Linguistic and Cognitive Engineering (DOLCE) (Borgo & Masolo, 2010), as the top-level ontology for mathematics that exhibits a part of the ontological region of abstract entities (Herre & Loebe, 2005).<sup>5</sup> Abstract objects as introduced by Zalta (1983) correspond to another example in the region of abstract entities in GFO. The other ontological regions that are addressed in GFO are classified into the psychological, the material, and the social ontological region.<sup>6</sup>

The most difficult methodological problem concerning the introduction of axioms is their justification. In general, four basic problems are related to an axiomatization of the knowledge of a domain (cf. also Baumann & Herre, 2011, esp. sect. 2).

1. What are adequate / appropriate concepts and relations of a domain? (*conceptualization problem*)
2. How may we find axioms? (*axiomatization problem*)
3. How can we know that our axioms are true in the considered domain? (*truth problem*)
4. How can we prove that our theory is consistent? (*consistency problem*)

In the remainder of this section we summarize basic notions and theorems from model theory, logic and set theory which are relevant for this paper, in particular for the meta-logical analyses. These notions are presented in standard text books, such as those by Barwise & Feferman (1985), Chang & Keisler (1990), Devlin (1993), Enderton (1993), Hodges (1993), and Rautenberg (2010).

<sup>4</sup>Most mathematicians accept the fundamental status of set theory. To be more explicit, set theory plays the role of a core ontology for mathematics. This does not mean that any mathematical discipline is a part of set theory, but only that arbitrary mathematical notions can be reconstructed in the framework of set theory. Furthermore, we note that there are competing core ontologies for mathematics, for example, mathematical category theory.

<sup>5</sup>The ontological character of abstract entities, presented in set theory, is uncovered by the mysterious phenomenon of the practical applicability of mathematics in the field of material objects, in particular in physics (Wigner, 1960).

<sup>6</sup>There is the problem of how these four ontological regions are connected. At present, we adhere to the view that there is the following more precise classification: (1) temporal-spatial reality, subdivided in spatio-temporal material entities, and temporal mental-psychological and sociological entities, (2) entities being independent of space and time, but dependent on the mind, e.g., concepts, (3) ideal entities which are independent of space and time, and exhibit an objective world of their own, independently of the mind. A similar classification is discussed by Roman Ingarden (1964).

A logical language  $\mathcal{L}$  is determined by a syntax specifying its formulas and by a semantics. Throughout this paper we use first-order logic (FOL) as a framework. The semantics of FOL is presented by relational structures, called  $\sigma$ -structures, which are interpretations of a signature  $\sigma$  consisting of relational and functional symbols. We use the term model-theoretic structure to denote first-order relational structures. For a model-theoretic structure  $\mathcal{M}$  and a formula  $\phi$  we use the expression  $\mathcal{M} \models \phi$  to mean that the formula  $\phi$  is true in  $\mathcal{M}$ . A structure  $\mathcal{M}$  is called a model of a theory  $\mathcal{T}$ , being a set of formulae, if for every formula  $\phi \in \mathcal{T}$  the condition  $\mathcal{M} \models \phi$  is satisfied. Let  $Mod(\mathcal{T})$  be the class of all models of  $\mathcal{T}$ . Conversely, we define for a class  $\mathcal{K}$  of  $\sigma$ -structures the theory of  $\mathcal{K}$ , denoted by  $Th(\mathcal{K})$ :  $Th(\mathcal{K}) = \{\phi \mid \mathcal{A} \models \phi \text{ for all } \mathcal{A} \in \mathcal{K}\}$ . The logical consequence relation, likewise denoted by  $\models$ , is defined by the condition:  $\mathcal{T} \models \phi$  if and only if  $Mod(\mathcal{T}) \subseteq Mod(\{\phi\})$ . In that case  $\phi$  is called a consequence or a theorem of  $\mathcal{T}$ . If a theory  $\mathcal{T}$  is specified axiomatically, i.e., by a set of postulated formulas, called axioms, the notion of theorem is usually restricted to formulas  $\phi$  satisfying  $\mathcal{T} \models \phi$ , but which are not axioms.

For first-order logic the completeness theorem holds:  $\mathcal{T} \models \phi$  if and only if  $\mathcal{T} \vdash \phi$ , where the relation  $\vdash$  is a suitable formal derivability relation. The operation  $Cn(\mathcal{T})$  is the classical closure operation which is defined by:  $Cn(\mathcal{T}) = \{\phi \mid \mathcal{T} \models \phi\}$ . A theory  $\mathcal{T}$  is said to be decidable if there is an algorithm Alg (with two output values 0 and 1) that stops for every input sentence and satisfies the condition: For every sentence  $\phi$  in the language of  $\mathcal{T}$ :  $\mathcal{T} \models \phi$  if and only if  $Alg(\phi) = 1$ . An extension  $\mathcal{S}$  of a theory  $\mathcal{T}$  is said to be complete if for every sentence  $\phi$ :  $\mathcal{S} \models \phi$  or  $\mathcal{S} \models \neg\phi$ . A complete and consistent extension of  $\mathcal{T}$  is called an elementary type of  $\mathcal{T}$  (type of  $\mathcal{T}$ , for short). Assuming that the language  $\mathcal{L}$  is countable then there exists a countable set  $X$  of types of  $\mathcal{T}$  such that every sentence  $\phi$  which is consistent with  $\mathcal{T}$  is consistent with a type from  $X$ . In this case we say that the set  $X$  is dense in the set of all types of  $\mathcal{T}$ . Determining such a set of types defines the classification problem for  $\mathcal{T}$ , which is solved if a reasonable description of a countable dense set of types is presented.

## 2. Time in Logic, Artificial Intelligence, and Ontologies

The literature on time and temporal representation and reasoning is vast. We merely point to some of the corresponding surveys (Benthem, 1995; Fisher, Gabbay, & Vila, 2005; Gabbay & Guenther, 2002; Galton, 2008) and strictly limit the scope of what follows to works closely related to the present paper.

### 2.1. Axiomatic Theories of Time

Axiomatizations of time have been studied primarily in artificial intelligence. Recently, Lluís Vila surveyed time theories according to three major branches: purely point-based and purely interval-based theories, plus theories that combine points and intervals (Vila, 2005). An earlier catalog of temporal theories is provided by Patrick J. Hayes (1995). Very recently, several of these and further theories have been implemented, verified and further formally analyzed regarding their metatheoretic relationships by Michael Grüninger et al. (cf. Grüninger & Ong, 2011).

The claimed focus of Vila's survey is on "the most relevant theories of time proposed in Artificial Intelligence according to various representational issues [...]" (Vila, 2005, p. 1). Additionally, its introduction links to many, frequently more specific works on time. For pure point-theories, Vila mainly presents typical axioms for a single relation *before* (time point  $x$  is properly before time point  $y$ ): those of a linear order, unboundedness/infinity in both directions and the mutually exclusive axioms of discreteness (every time point has an immediate successor and predecessor) and density (between any two distinct time points there is a third one). This allows for interesting completeness results: if *before* is axiomatized as an unbounded, strict linear ordering and satisfies either discreteness or density, that yields a syntactically complete theory already (Benthem, 1991).

In the case of purely interval-based theories, there is a similar result on an extended version of the interval theory of James F. Allen and Patrick J. Hayes (1985; 1989), referred to as  $\mathcal{AH}$  in (Vila, 2005). In (1983), Allen had introduced a temporal interval algebra (cf. also Fisher et al., 2005, ch. 8) that is based

on disjunctive combinations of the 13 well-known simple qualitative interval relations, including *equal*, *meets*, *before/after*, *starts/ends*, *overlap*, etc. Allen and Hayes then provided a FOL axiomatization of *meets* consisting of five axioms, and showed that the remaining 12 relations can be defined solely based on *meets*.<sup>7</sup> Together with an additional axiom enforcing a kind of density of the meeting points of time intervals, Peter Ladkin presents an extension to  $\mathcal{AH}$  which he proved to be complete (1987).

Despite the valuable results on pure interval theories, they are frequently considered to be insufficient unless time points are reintroduced or reconstructed (Balbiani, Goranko, & Sciavicco, 2011; Vila, 2005, sect. 1.6–1.7). Reconstruction is typically mathematical in nature, e.g. by defining points as maximal sets of intervals that share a common intersection. In contrast, theories have been proposed that genuinely consider time points and intervals on a par. One example is the theory  $\mathcal{IP}$  by Lluís Vila (1994; 2005, sect. 1.7.2), which extends the axioms of the pure point theory (without fixing density or discreteness) with seven axioms that naturally link points and intervals using the point-interval relations *begin* and *end* (time point  $x$  is the begin/end of interval  $y$ ).  $\mathcal{IP}$  enjoys interesting metalogical properties: firstly, every model of  $\mathcal{IP}$  is completely characterized by an infinite set with an unbounded strict linear order on it; secondly, the theory  $\mathcal{IP}_{\text{dense}}$ , obtained by adding density of time points to  $\mathcal{IP}$ , is logically equivalent to Ladkin's complete extension of  $\mathcal{AH}$  (Vila, 2005, p. 7, 16–17).

In summary, these are well-established and important theories to which each new proposal should be related (cf. section 7). Notably, there are various further theories which consider additional, frequently more controversial and/or purpose-driven views on time, e.g. directedness of time intervals (Hayes, 1995, sect. 5.3), branching time approaches, etc., which cannot be covered here.

Regarding time regions, we are not aware of any pure first-order axiomatization in the domain of time that considers points and/or intervals as well as mereological sums or, more generically, aggregates of them. Parts of the work on OWL-Time (Hobbs & Pan, 2006), (cf. more specifically ?, especially ch. 4), which is a proposal of a time theory for the Semantic Web and thus primarily represented in the Web Ontology Language (OWL) (W3C, 2012), may be most closely related. OWL-Time is a continuation of (?). It is based on a combined point and interval theory axiomatized in FOL that includes Allen's interval relations, and in addition considers time durations, descriptions of calendar dates and times, as well as temporal aggregates (? , sect. 6), all of which appears to be covered and linked to proposals for the Semantic Web in (? , with temporal aggregates in ch. 4). However, those axiomatizations are claimed to “make moderate use of second-order formulations” (? , sect. 4.1, p. 42), and they presuppose some set theory (? , sect. 6.1) due to introducing the aggregate notion of “temporal sequence” as referring to a set of temporal entities with a temporal ordering over their elements, in contrast to conceiving of “temporal sequence” as a mereological sum. These are clear deviations from the theory  $\mathcal{BT}^{\mathcal{R}}$  as introduced in sections 8 and 9 below. Finally, some spatio-temporal theories comprise mereotopological axioms (e.g., cf. ?), but they have a different domain than pure time entities (and may rely on very different foundations). Hence, spatio-temporal theories are out of the scope of this section. Nevertheless they are of interest in future work, not at least in connection with the spatial theory of GFO Baumann & Herre (2011).

## 2.2. Time in Top-Level Ontologies

In the context of top-level ontologies, time entities like time points or intervals are usually classified within the corresponding taxonomic structure, but specific theories of time are developed in rare cases (and if so, they often adopt the theories just introduced). Due to spatial limitations, we restrict a closer look to DOLCE (Borgo & Masolo, 2010; Masolo, Borgo, Gangemi, Guarino, & Oltramari, 2003, mainly ch. 3–4), BFO (Spear, 2006), and PSL (Grüninger, 2004; ISO TC 184, 2004).<sup>8</sup>

<sup>7</sup>Although the axiomatization uses FOL with equality, it is stated that the *equal* relation can be defined by a simple adaptation of one axiom (Allen & Hayes, 1989, p. 228).

<sup>8</sup>The acronyms stand for Descriptive Ontology for Linguistic and Cognitive Engineering (DOLCE), Basic Formal Ontology (BFO), and Process Specification Language (PSL); the respective websites are:  
<http://www.loa.istc.cnr.it/DOLCE.html> ,  
<http://www.ifomis.org/bfo> ,  
<http://www.mel.nist.gov/psl> .

Time is included in DOLCE through the category *temporal region*, which is subsumed by the category *abstract* [entity]. Temporal regions are subject to a general, atemporal parthood relation. Temporal localization is a special case of quality assignment in DOLCE, involving *temporal qualities* whose values are temporal regions, themselves part of the temporal space. Deliberately, no further assumptions about the temporal space are made in order to remain neutral about ontological commitments on time (Borgo & Masolo, 2010, p. 287).

BFO (Masolo et al., 2003, ch. 7–8; Spear, 2006) includes the disjoint categories *temporal interval* and *instant* as subcategories of *temporal region* and *occurrent*. Any temporal region is part of *time* (the whole of time). A few initial axioms for time in BFO are available (Masolo et al., 2003, ch. 8; Trentelman, Ruttenberg, & Smith, 2010). Axiomatic interval theories do not seem to be included or adapted. Some axioms in (Trentelman et al., 2010, sect. 5.1) suggest that time instants are linearly ordered, mereology is applied to temporal regions, and there is a link with the notion of boundaries (as introduced e.g. in Smith & Varzi, 2000), by requiring that instants can only exist at the boundary of temporal intervals (Trentelman et al., 2010, sect. 5.1).

PSL (Grüniger, 2004; ISO TC 184, 2004) aims at process modeling and is thus related with time. This ontology is highly modularized and completely presented as a FOL axiomatization, with verified consistency for some modules. The core module of the PSL ontology distinguishes *activity*, *activity occurrence*, *object*, and *time point*; further there is a module for time duration. The relation *before* on time points forms an infinite linear order, with “auxiliary” bounds  $+\infty$  and  $-\infty$ . Density and discreteness are not assumed in the core of PSL, but may be added as an extension. Eventually, we are not aware of any extensions covering intervals and/or interval relations within PSL. However, there are a number of modules axiomatizing mereological, ordering, and duration relations for activities/activity occurrences.

### 3. Motivating Problems and Requirements for Time in GFO

First of all, an ontology of time should establish a rich basis for analyzing temporal phenomena. In this section we describe four time-related problems with open issues that lead to further demands on a time ontology. These *motivating* problems are reconsidered in section 5, necessarily in connection with additional categories of entities such as processes or continuants.

#### 3.1. The Holding Problem of Temporal Propositions

The holding problem of temporal propositions (called temporal incidence, e.g. by Reichgelt & Vila (2005); Vila (2005)) is concerned with domain-independent conditions that determine the truth-value of propositions through and at times. One aspect of temporal incidence theories is to account for interrelations of propositions holding at different time entities, e.g. *homogeneity* (cf. Allen, 1984, sect. 2). Such conditions can be expressed using relations like *holds*( $\phi, t$ ), referred to as temporal incidence predicates in (Vila, 2005, p. 19). Their intended meaning is that the proposition  $\phi$  is true at time entity  $t$ . We argue that propositions can hold at time intervals and/or at time points. Considering the tossing of a ball (see Figure 1), for example, *the velocity of the ball is zero* holds at one time point, *the ball is raising* holds at an interval (and maybe at many points), *the tossing takes 10 seconds* applies only to an interval.

At the center of these problems is the development of a truth relation between propositions and spatio-temporal reality. The ontology of time appears as a constituent of an ontology of concrete material entities. We must develop an ontology of parts of reality / parts of the world which can serve as truth-makers for propositions (eventually as expressed by natural language sentences). In these regards, the relation *holds*( $\phi, t$ ) with the meaning that the proposition  $\phi$  holds at time  $t$  is insufficiently specified. A further argument  $s$  is required, and a ternary relation, denoted by *holds*( $\phi, t, s$ ) with the meaning:  $\phi$  holds at time  $t$  in  $s$ , where  $s$  is a part of the world that includes a time component. According to GFO, the entity  $s$  can be considered as a temporally extended situation, also called *situoid*, cf. (Herre, 2010, sect. 14.4.6), (Herre et al., 2007, sect. 12). A situoid  $s$  provides a temporal frame of reference through its time component.

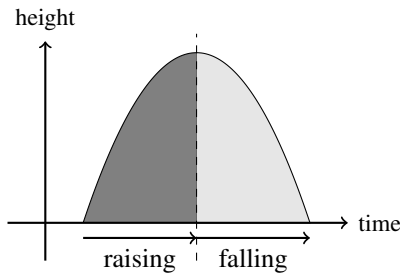

Figure 1. Tossing a ball into the air.

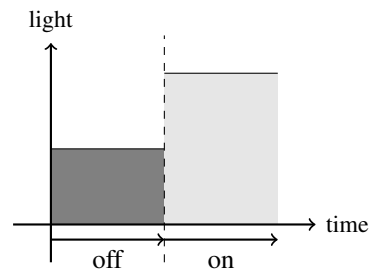

Figure 2. Switching on the light.

There are propositions without any reference time, for example,  $2 + 2 = 4$ . Others have a time aspect, for example, the proposition *the tossing of this ball takes 10 seconds*. Let us briefly go into some detail in this case: One may imagine a temporally extended situation  $s$  which contains several entities, for example, a ball, a throwing person, and the throw itself. The throw is a process, actuated by this person and having a ball as participant. This process has a duration of at least 10 seconds. It is embedded into the situoid  $s$ , hence this situoid must possess a time frame with a duration of at least 10 seconds. Intuitively, we may say that the proposition is satisfied in  $s$  (alternatively, that  $\phi$  is true in  $s$ , or that  $s$  is a truth-maker for  $\phi$ ). Some corresponding requirements are formulated in the context of an initial outline of an *ontological semantics* (see Loebe & Herre, 2008, esp. sect. 3). There are related further issues at the side of languages. We need an explication of elementary sentences (or atomic propositions), and of rules for combinations of elementary sentences to more complex expressions. Even the notion of elementary sentence is a non-trivial and unsolved problem, cf. e.g. criticism by Ludwig Wittgenstein (1989).

In summary, the current theory of temporal incidence reveals many open problems. Relevant basic notions are insufficiently founded, for example, the incidence relation *holds* and the notion of an atomic proposition (or elementary sentence). Moreover, the holding of negation, conjunction and disjunction of temporal propositions is a non-trivial problem, cf. (Vila, 2005, p. 5). These matters clearly deserve further treatment in future work, while an ontology of time should support the natural expression of temporal incidence conditions and/or the translation of a proposition of a language to an ontologically founded formal sentence.

### 3.2. The Dividing Instant Problem

One famous problem involving the holding of propositions shall be given special attention: it is termed Dividing Instant Problem (DIP), e.g. in (Allen, 1983), or the problem of the Moment of Change (MOC) (Strobach, 1998) or Instant of Change (Galton, 1996). Allen illustrates it by *switching on the light* (1983), see Figure 2. The central question (in this exemplary case) is whether the light is off or on at the switching point, assuming instantaneous changing from off to on. One might claim that the light is both, off and on, or it is neither off, nor on. Logically, the former leads to an inconsistency, the latter violates the law of the excluded middle. The two remaining basic options are, firstly, to argue for a specific choice of either off or on to apply at the dividing instant, and secondly, to let exactly one of off or on apply, without defending any particular choice, i.e., allowing for an arbitrary selection. More complexity can be added if several types of dividing instants are distinguished and treated differently according to the basic options just mentioned, e.g. cf. “Neutral Instant Analysis” surveyed in (Strobach, 1998).

There are several proposals to solve the DIP/MOC. Niko Strobach has devoted a whole book to the treatment of the problem in philosophy, including a novel contribution by himself (1998). His “systematic history” of the MOC starts with the views of Plato and Aristotle and is further covering medieval approaches and the twentieth century. As summarized by Jansen (2001), there are representatives in the twentieth century for each of the four basic options introduced above. Antony Galton has authored another survey on the DIP (1996) that, besides philosophy, captures mathematical views as well as accounts in artificial intelligence. Focusing on the latter, we note that Allen’s solution excludes instants from the time

ontology, and claims that propositions do not satisfy the condition to be true at a time point. We reject this as a general approach due to the implicit reduction of propositions, in the light of the previous section. Another approach stipulates that all intervals are semi-open, e.g. left-closed and right-open (Maiocchi, Pernici, & Barbic, 1992). Then, if a proposition is true throughout a time interval and is false throughout a subsequent interval, the truth-value at the dividing instant is false. A weakness of this approach is the arbitrary choice between employing left-closed and right-open vs. left-open and right-closed intervals.

As the case of switching on the light illustrates, the following conditions describe a common situation that needs to be captured:

1. There are two processes following one another immediately, i.e., without any gaps (the process *light off* meets *light on*)
2. There is a last point  $t_l$  in time where the first process ends and there is a first point  $t_f$  in time where the second process starts.
3. The points  $t_l$  and  $t_f$  are distinct.

An adequate solution to the DIP can be achieved through an ontology of time points and intervals that allows for satisfying these conditions, due to supporting the consecutiveness of processes without any overlap. Note that these conditions cannot be satisfied if we represent time by the ordering of real numbers, the usual understanding of the continuum since the work of Richard Dedekind (1872) and Karl Weierstrass (cf. Grabiner, 1983).

### 3.3. *The Continuum*

The continuum has two sources, phenomenal time and phenomenal space, and it can be accessed through introspection. Phenomenal time is a subjective assumption of any movement, therefore, one origin of the notion of continuum is closely related to the movement of a body. We adopt the position that the notion of continuum is abstracted from subjective temporal (and spatial) phenomena. The result of this abstraction – according to our approach – can be accessed through a particular kind of introspection, which Immanuel Kant calls *reine Anschauung* (1787/2006, I.§1).<sup>9</sup>

Franz Brentano (1976) criticizes the approach taken by Dedekind and Weierstrass to construct the continuum by using numbers, more precisely by means of the rational numbers and infinite sequences of rationals. The problems associated with the classical mathematical approach to the continuum can be demonstrated by one of Zeno's paradoxes, the Paradox of the Arrow (cf. Huggett, 2010, esp. sect. 3.3). Consider an arrow  $a$  flying from location  $l_1$  to another location  $l_2$  during the time interval  $I = [t_1, t_2]$ . For the subsequent argument, we assume that the interval  $I$  equals the set of time points of  $I$ , and in particular, that these time points can be represented by real numbers. It is immediately clear that  $a$  cannot move at any time point, because time points have no temporal extension. If the interval  $I$  equals the set of time points of  $I$ , and  $a$  does not move at any time point (neither at  $t_1$ ,  $t_2$ , or any in between), then this implies that  $a$  does not move at all, in particular, it cannot move from location  $l_1$  to location  $l_2$ . From these considerations, independently of and in addition to those at the end of the previous section 3.2, one may conclude that the idea of identifying an interval with its set of points cannot be further maintained.

An exhaustive discussion of the continuum problem, from the historical perspective and the view of contemporary mathematics is presented in (Bell, 2006).

<sup>9</sup>In general, introspection means to look into one's own mind, to find what one thinks and feels. In our opinion, the notion of continuum can be grasped by a particular form of introspection, following Kant. There is a related debate about the a priori nature of time and space. According to Kant (1787/2006), time is an a priori notion, accessible without any experience of reality. In contrast, Franz Brentano believes that all notions are based on experience, hence there are no a priori notions (cf. Brentano, 1874/2008, 1925). We advocate the thesis that both theories can be reconciled in the framework of *integrative realism* (Herre, 2010, esp. sect. 14.2.6), (Herre, 2013, esp. sect. 6). (Section 5.4 below comprises more details on this form of realism.)



### 3.4. Persistence and Change

Another problem, which lacks a comprehensive solution and rests upon a tailored ontology of time, concerns entities that persist through time, though, exhibit different properties at different times. What does it mean that an entity is identical through time, and concurrently changes its properties?

Possibly to an even greater extent than in the case of the DIP, there are several approaches to cope with the problem of persistence and change. David Lewis (1986) classifies entities into *perdurants* and *endurants* (also termed *continuants* in the literature). An entity perdures if it persists by having different temporal parts, or stages, at different times, whereas an entity endures if it persists by being wholly present at any time of its existence. Persistence by endurance is paradoxical and leads to inconsistencies (Barker & Dowe, 2005). Furthermore, the stage approach exhibits serious weaknesses (Wahlberg, 2008). Both of these interpretations and explanations of the phenomenon of persistence are criticized by various arguments, while further alternatives, e.g. as discussed by Sally Haslanger (2003), reveal shortcomings, as well. Consequently, the development of a satisfactory, widely acceptable theory of persistence remains an open problem.

Let us demonstrate some of the problems related to persistence in greater detail. A (material) continuant persists through time and is wholly present at every point of its life time, which is a temporally extended interval. This is obviously paradoxical, because if a continuant is wholly present at one time point, then the same entity, being a spatio-temporal, material individual, cannot be wholly present at another time point. This argument assumes the condition that a spatio-temporal individual cannot be multi-located as a whole throughout a 4D region.

On the other hand, the doctrine of endurantism claims the existence of spatio-temporal individuals that are multi-located in space and time, hence they are wholly present and located at distinct space-time regions. Stephen Barker and Phil Dowe (2005) show that endurantism leads to various paradoxes, which are reduced to the problem of how the individuals that are located at distinct spatio-temporal regions are related to the continuant / endurant as such. First, one may distinguish the continuant  $c$  in itself and individuals  $c(t)$ , each of which is determined by the location of  $c$  at spatio-temporal regions  $t$ . The definition of endurantism yields  $c = c(t)$ , for every region  $t$  at which  $c$  is located (ibid., p. 69).

On this basis, one of the paradoxes (ibid., p. 69–70) derives from the assumptions that (i)  $c$  is also identical with the mereological fusion of all  $c(t)$  and (ii) all regions  $t$  are assumed to have distinct time intervals as their temporal coordinates. Now a problem arises for the temporal extent of the mereological fusion of all  $c(t)$ . On the one hand, selecting any  $t$ , the fusion should have a temporal extent as is the case for  $t$ , because the fusion is identical with  $c$  and thus with  $c(t)$ . On the other hand, the mereological fusion has all the  $c(t)$  as its parts, hence the temporal extent of the fusion should be the sum of all their corresponding time intervals. This yields a paradox if at least two  $c(t)$  with distinct regions are assumed.

In the case that the temporal coordinates of the regions  $t$  are assumed to be time points (instead of extended intervals), another paradox is derived in (ibid., p. 70). The time point assumption implies that  $c$  itself has no temporal extension, due to  $c = c(t)$ , i.e.,  $c$  is a 3D object – contrary to the presupposition that  $c$ , as a continuant, has a non-zero life time. These paradoxes can be avoided if we assume that  $c \neq c(t)$ , that  $c(t)$  are entities of their own, and that the relation between  $c$  and the  $c(t)$  is not the part-of relation.

A solution to the mentioned problems may be found in the stage approach, which states that an entity persists by perdurance because it is temporally extended by having stages at different times. Stages, in this sense, are small processual parts, whereas the whole perdurant is a mereological sum of these stages (Sider, 2001). However, this approach to persistence leads to new problems, if we attempt to formalize stage structures. The following questions must be answered: Are the stages linearly ordered? They should be, because we assume that a stage  $s$  occurs before (or after) another stage  $t$ . But if they are linearly ordered, one may ask which order-type these structures possess. Is there another stage between any two different stages? If the ordering is a dense ordering there may be problems with the measurements of the duration of intervals, due to stages being temporally extended (Becher, Clérin-Debart, & Enjalbert, 2000).

---

wholly multi-located  
→ multi-located as a  
whole

---

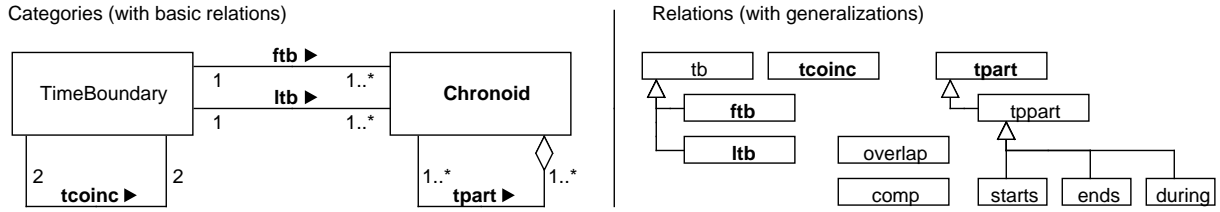

Figure 3. Categories and relations of the time theory  $\mathcal{BT}^C$  of GFO. Boldface signifies primitives.

## 4. Time in GFO and Basics of the Material Stratum

### 4.1. $\mathcal{BT}^C$ – An Ontology of Chronoids, Boundaries and Coincidence

The basic theory of phenomenal time in GFO is abstracted from real-world entities and is inspired by ideas of Franz Brentano (1976); we refer to it as  $\mathcal{BT}^C$ . Figure 3 provides an overview of its relevant categories and relations, using for relations the mnemonic predicate names introduced in section 6. Abstract phenomenal time consists of intervals, named *chronoids*, and of *time boundaries*, i.e., time points (roughly speaking). Both are genuine types of entities, where time boundaries depend existentially on chronoids. Only chronoids are subject to *temporal parthood*, and Allen’s interval relations (see section 2) apply to them. Every chronoid has exactly two extremal boundaries, which can be understood as the *first* and *last* time point of it. Further, chronoids are truly extended and have infinitely many *inner time boundaries* that arise from proper subchronoids.

An outstanding and beneficial feature of  $\mathcal{BT}^C$  is the relation of *temporal coincidence* between time boundaries, adopted from Brentano. Intuitively, two coinciding time boundaries have temporal distance zero, although they may be distinct entities. By their means, if a chronoid  $c_1$  *meets* a chronoid  $c_2$ , both have distinct extremal boundaries without any overlap or gaps between the last boundary of  $c_1$  and the first of  $c_2$ . Time boundaries coincide pairwise. Section 6 captures these and further details of  $\mathcal{BT}^C$  axiomatically, from which it is derivable, among others, that time is linear and unbounded, see section 7.

### 4.2. Basics of GFO Related to the Material Stratum

A few further remarks on GFO are required before revisiting the motivating problems from above in section 5. First of all, GFO adopts the theory of levels of reality, as expounded by Nicolai Hartmann (1935–1950) and Roberto Poli (2001). We restrict the exposition to the *material stratum*, the realm of entities including individuals that are in space and time.

According to their relations to time, individuals are classified into *continuants* (being material endurants), material *presentials* and material *processes*. Processes happen in time and are said to have a temporal extension. Continuants persist through time and have a lifetime, which is a chronoid. A continuant exhibits at any time point of its lifetime a uniquely determined entity, called presential, which is wholly present at the (unique) time boundary of its existence.<sup>10</sup> Examples of continuants are this ball and this tree, being persisting entities with a lifetime. Examples of presentials are this ball and this tree, any of them being wholly present at a certain time boundary  $t$ . Hence, the specification of a presential additionally requires the declaration of a time boundary.

In contrast to a presential, a process cannot be wholly present at a time boundary. Examples of processes are particular cases of the tossing of a ball, a 100 m run as well as a surgical intervention, the conduction of a clinical trial, etc. For any process  $p$  having the chronoid  $c$  as its *temporal extension*, each temporal

<sup>10</sup>Despite employing the widely used term ‘continuant’, this notion is very specific in GFO. For instance, continuants are not wholly present at time boundaries. Note that earlier accounts of this approach made use of different terms, e.g. *abstract substance* (Heller & Herre, 2004) and *perpetuant* (Herre, 2010).

part<sup>11</sup> of  $p$  is determined by taking a temporal part of  $c$  and restricting  $p$  to this subchronoid. Similarly,  $p$  can be restricted to a time boundary  $t$  if the latter is a time boundary or an inner boundary of  $c$ . The resulting entity is called a *process boundary*, which does not fall into the category of processes.

## 5. New Modeling Contributions to Temporal Phenomena

Based on the previous section, we outline new approaches or contributions to tackling the motivating problems from section 3.

### 5.1. The Holding Problem of Temporal Propositions

Altogether, we propose the ontology  $\mathcal{BT}^C$  as a solid foundation for the analysis of temporal phenomena. It appears immediate from section 4.1 that it provides at least the conceptual means that are known from point-interval theories. The existence of a formal theory interpretation of the theory  $\mathcal{IP}$  (and thus  $\mathcal{AH}$ , see section 2) into  $\mathcal{BT}^C$  provides a formal underpinning to this intuition, see section 7.3. Beyond common features, a major novel aspect of  $\mathcal{BT}^C$  is the notion of coincidence.

Coincident time boundaries are important regarding the holding of temporal propositions. They allow for the case that a proposition holds at a time boundary, but it does not hold at its coincident time boundary. In general, the temporal incidence problem is a special case of a more general problem, namely, to construct a semantic basis for propositions of a language. We argue that such semantic foundation should use an ontological framework, making the content of linguistic expressions explicit, for first steps see (Loebe & Herre, 2008; Neumuth, Loebe, Herre, & Neumuth, 2011). This will further involve the notion of truthmakers, present in GFO as facts, being constituents of situations or situoids (Herre et al., 2007). The overall approach is inspired by several sources, among them Ludwig Wittgenstein's *Tractatus Logicus* (1969) and mainly the situation theory of Jon Barwise and John Perry (1983) (cf. also Devlin, 2006). Much of the research on GFO in these regards is in progress, as well as work regarding temporal incidence itself.

### 5.2. The Dividing Instant Problem (DIP)

The DIP finds clear and conclusive solutions based on  $\mathcal{BT}^C$ , to the extent that the latter provides an expressive foundation for capturing circumstances that “instantiate” the DIP in analysis and applications. At least three of the four basic replies to the DIP can be implemented on this basis.

First, let us return to the example of switching on the light (Figure 2). The corresponding analysis yields two processes  $p$  and  $q$ , where  $p$  is extended over a chronoid with last boundary  $t_l$  and  $q$  stretches over a chronoid with first boundary  $t_f$ . We may consistently stipulate that all process boundaries of  $p$  exhibit the property *light-off*, whereas *light-on* applies to all of  $q$ , and  $t_l$  and  $t_f$  are distinct, but coincide. This exactly satisfies the requirements set forth at the end of section 3.2.

In this situation there are two properties, contradicting each other, and holding at two different time points having temporal distance zero. This analysis is adequate because abstract phenomenal time, exhibiting the phenomenon of coincidence, is accessible introspectively without any metrics, whereas the notion of distance is a result of measuring by using an abstract scale of numbers.

The analysis just provided corresponds to the solution of the DIP that the light is “both, on and off” at the dividing “instant” where  $p$  and  $q$  meet, as which one may consider the pair of coincident boundaries  $t_l$  and  $t_f$ . Note that the logical framework remains purely classical, including the law of non-contradiction (applicable to each time boundary, whereas pairs of coincident boundaries are not under consideration). The cases of making a specific choice for the dividing instant or allowing for an arbitrary selection both

<sup>11</sup>Notably, there are other dimensions by means of which parts of processes can be considered, cf. layers of processes in (Herre et al., 2007, sect. 8.2.4).

correlate with the temporal assignment of one and the same property or proposition to both time boundaries.

The remaining approach to the DIP was to assume neither on nor off as applicable to the dividing “instant”. One interpretation of this view may just be the one above, where each time boundary is assigned on or off, while no uniform statement can be aggregated from the individual time boundaries to the pair of coincident time boundaries. Alternatively and taking “neither on nor off” more literally, we reject logical modifications such as revoking the law of the excluded middle as well as “gaps” in assigning propositions to time boundaries, cf. section 3.1. For instance, regarding “(not) to be at maximum height” in the example of tossing a ball into the air (Figure 1), its positive manifestation applies solely at the last time boundary of raising and the first time boundary of falling, which coincide. Moreover, there is no last time boundary in raising to which the negative manifestation applies, nor any such first time boundary in falling.

### 5.3. *The Continuum*

Regarding the continuum itself, actually no *additional* contribution arises from the time ontology adopted in section 4. However, we stress the inspiration from Brentano’s work (1976). His criticism of defining the continuum by the set of real numbers is based on the conviction that the continuum – which is considered by him as a notion that is abstracted from experience – cannot be constructed from numbers by a transfinite inductive procedure. We adopt and defend the corresponding position that the real numbers cannot be identified with the structure of phenomenal time, in contrast to wide-spread “mathematicists” views (cf. Galton, 1996, sect. 2–3). Notably, we do not generally deny the applicability and utility of the typical mathematical modeling of time. Rejecting the said identification rather amounts to a change in the foundation and interpretation of such modeling. Finally, the interpretation of the continuum by means of real numbers provides a metric for time as a basis for measurements.

### 5.4. *Persistence and Change*

A further application of the ontology of time just presented is given by being among the sources of the GFO approach to persistence. Yet the basic assumption of that approach is grounded on the idea of *integrative realism*, originally introduced in (Herre, 2010) and further pursued in (Baumann & Herre, 2011) and especially (Herre, 2013). We remark that a similar approach was pursued by the Chinese philosopher Zhang Dongsun, who established the philosophy of epistemological pluralism in his ground-breaking work (1934). The term *integrative realism* denotes a doctrine of realism which postulates that there exists a world, being existentially independent of the mind, but which can be accessed by the mind through mental constructions, called concepts. These mental constructions establish a correspondence relation between the mind (the subject) and the entities of the independent reality. This relation can be understood as *unfolding the real world disposition  $d$  in the mind’s medium  $m$ , resulting in the phenomenon  $p$* . The mind plays an active role in this relation.<sup>12</sup> This kind of realism fits well into the framework of levels and strata of reality (Hartmann, 1935–1950; Poli, 2001).

One approach to persistence by endurance refers to a conception of immanence, for which a particular class of universals is utilized. On the one hand, universals are independent of space and time and, consequently, they may be said to persist, in some sense. On the other hand, they have a relation to space and time via their spatio-temporal instances. The idea of accounting for persistence in terms of immanence via universals was pursued with the notion of *persistant* in an earlier version of GFO, cf. (Herre, 2010, esp. sect. 14.4.2), (Herre et al., 2007, esp. sect. 6, 10). However, universals are not individuals, and we prefer to understand and accept continuants as individuals.

The latest and stable solution to the persistence problem in GFO rests on the following ideas. There is a new<sup>13</sup> class of individuals, called *presentials*. Each presential is wholly present at a single, fixed time

<sup>12</sup>The investigation of this type of relation is in its initial stages. It can be associated with the mind-body problem (Robinson, 2012; Taylor, 2010).

<sup>13</sup>“new” compared to common accounts distinguishing between the two categories of continuants / endurants and perdurants.

boundary. *Continuants* constitute another class of individuals. They are cognitive creations of the mind, constructed on the basis of presentials. The idea of the mental creation of continuants from presentials is expounded in more detail in (Herre, 2013, esp. sect. 7.2), and it is claimed that this cognitive construction is grounded on, eventually, personal identity. According to this account, continuants possess features of a universal, occurring as the phenomenon of persistence, but also of spatio-temporal individuals, by being grounded in presentials. We say that a continuant *c* exhibits a presential *p*, if *p* exists at a time boundary *t* and *p* corresponds to conceiving of *c* at *t* (or as viewing *p* as a “snapshot” of *c* at *t*). At every time boundary within its life time a material continuant exhibits a presentic material structure. Continuants may change, because (1) they persist through time and (2) they exhibit different properties at distinct time boundaries of their lifetime (due to exhibiting different presentials). We argue that only persisting individuals may change. Presentials are not subject to change since they exist at unique times / time boundaries. A process as a whole cannot change either, but it may comprise changes or it may be a change. Hence, *to change* and *to have a change* or *to be a change* are different notions.

In GFO, each process has processual boundaries, which can be understood as the restrictions of the process to the time boundaries of its temporal extension. A process is neither the mereological sum of its boundaries, nor can it be identified with the set of its boundaries.<sup>14</sup> There is no way to construct a process from process boundaries, because processes are the more fundamental kind of entity in GFO. Indeed, and similarly to the relation of time boundaries and chronoids, process boundaries are (specifically) existentially dependent on their processes. Presentials participate in processes. More precisely, a presential *p* participates in a process if and only if there is a boundary of the process of which *p* is a part (which includes the case that *p* itself is the process boundary).

The following principle is stipulated for GFO, linking the notions of continuant, presential, and process. It is a core feature that is unique to GFO compared to the top-level ontologies in section 2.2, but also others. A more formal version in a more elaborated setting is expounded in (Herre, 2013, esp. sect. 7.1).

**Principle of Object-Process Integration** Let *c* be a material continuant. Then there exists a uniquely determined material process, denoted by *Proc(c)*, such that the presentials exhibited by *c* at the time boundaries of *c*'s lifetime correspond exactly to the process boundaries of *Proc(c)*; (cf. Herre, 2010, 2013; Herre et al., 2007).

We adopt the position that a continuant *c* depends on that process, on the one hand, and, on the other hand, on the mind, since *c* is supposed to be cognitively created in the framework of GFO. By this principle GFO integrates aspects of 3D and 4D ontologies into one coherent framework.

Let us emphasize that this approach differs from the stage theory as discussed by Theodore Sider (2001) and as in David Lewis' approach (1986), cf. also (Heller & Herre, 2004; Herre, 2013). For example, in stage theory processes are considered as mereological sums of stages, temporally extended entities, cf. also sect. 3.4. In contrast, processes in GFO do not have such stages as smallest parts. As discussed above, a process has process boundaries which are temporally located at time boundaries (and thus not extended) and which are not parts of their processes.

Finally, we find support for the GFO approach to continuants as cognitive constructions in results of cognitive psychology, notably in Gestalt theory (Wertheimer, 1912, 1922, 1923), but also others. For example, there are experiments in cognitive psychology that show that an observer identifies a moving entity through time (say, a running dog), even if this entity is occluded in the visual space during a suitably small amount of time (see Burke, 1952; Michotte, 1991). We believe that this phenomenon, known as the tunnel effect, supports the thesis of continuants as cognitive constructions.

<sup>14</sup>Of course, this set exists, but it is distinct from the process itself.

## 6. Axiomatization of the Ontology $\mathcal{BT}^C$

Section 4.1 introduces the major notions of the GFO time ontology of chronoids and their boundaries conceptually (e.g. recall Figure 3). The present section contains the corresponding axiomatic system  $\mathcal{BT}^C$  in first-order predicate logic with equality (FOL), followed by a metalogical analysis in section 7. The set of axioms reflects important properties of chronoids and time boundaries, assuming the domain of discourse is limited to these entities only.<sup>15</sup> The axiom set is not minimal, e.g. axiom A20 is entailed by others.  $\mathcal{BT}^C$  is available<sup>16</sup> in the syntax of the SPASS theorem prover<sup>17</sup> (Weidenbach et al., 2009), by means of which entailments were checked, including several further consequences, see section 6.3. We judge almost every axiom on its own to be easily comprehensible. Therefore, the axioms are presented compactly in the style of a catalog<sup>18</sup> with only short explanatory phrases.

### 6.1. Signature and Definitions

The signature splits into basic and defined symbols. The five basic predicates, highlighted through boldface in Figure 3, are introduced in Table 1 by means of atomic formulas in order to specify their intended informal reading with reference to argument positions through variables. Defined symbols are introduced in the context of their corresponding definition in D1–D12 below. For the purpose of reference, the list of definitions is sorted by the arity of symbols and alphabetically for the same arity.

The use of basic and defined symbols in those definitions is displayed in Table 2. Horizontal lines indicate boundaries between levels of dependence, where the definiens symbols of a certain level in the table use only basic symbols or such from the level(s) strictly above. The rows within each level are organized by the number of symbols in the definiens and, if that is equal, by definition number. Considering the vertical direction, the first column states the defined symbol and the associated definition number.<sup>19</sup> The second column on definiens symbols enumerates basic and defined symbols in the corresponding definiens by referring to the numbers of basic symbols and the numbers of definitions for defined symbols, respectively. The third column clusters symbol names into sets that contain exactly those symbols required in the definitions on the overall level. Altogether, Table 2 clarifies the interdependencies among defined symbols, in particular demonstrating their acyclicity through the three linearly ordered levels. Moreover, it yields orderings for reading the definitions consecutively and such that all symbols have been introduced before.

<sup>15</sup>Thus one cannot simply form the union of the present theory with other formalized components of GFO, but a corresponding relativation or even a theory interpretation will be required for combinations, e.g. cf. section 10.5.

<sup>16</sup><http://www.onto-med.de/ontologies/gfo-time.dfg>

<sup>17</sup><http://www.spass-prover.org>

<sup>18</sup>The actual axioms are arranged by adopting the complexity of formulas and mutual relations regarding content as guiding aspects, which also leads to the grouping into three types. Finally, note that all formulas are implicitly universally quantified.

<sup>19</sup>Note that the definitions D13 and D14 of the two starred symbols are only given in section 6.3. They are not used in any of the axioms A1–A34, but are included in Table 2 to show their dependencies, as well.

Atomic Formula	Intended Reading
B1. $Chron(x)$	$x$ is a chronoid
B2. $ftb(x, y)$	$x$ is the first boundary of $y$
B3. $ltb(x, y)$	$x$ is the last boundary of $y$
B4. $tcoinc(x, y)$	$x$ and $y$ are coincident
B5. $tpart(x, y)$	$x$ is a temporal part of $y$

Table 1  
Basic signature of  $\mathcal{BT}^C$ .

Definition	Definiens	Symbols	Clustered
$tov$	D9	B5	
$tppart$	D10	B5	
$ft$	D11	B2	(only basic signature elements in Table 1)
$lt$	D12	B3	
$comp$	D3	B1, B5	
$tb$	D8	B2, B3	
$meets$	D6	B1, B2, B3, B4	
$before^*$	D13	B1, B2, B3, B4	
$Tb$	D1	D8	{ $Chron$ ,
$ends$	D5	B1, B3, D10	$ftb$ , $ltb$ ,
$starts$	D7	B1, B2, D10	$tb$ , $tppart$ }
$TE$	D2	B1, D1	{ $Chron$ , $Tb$ ,
$during$	D4	B1, D5, D7, D10	$starts$ , $ends$ ,
$innerb^*$	D14	B1, D1, D8, D10	$tb$ , $tppart$ }

Table 2  
Defined signature with dependencies in  $\mathcal{BT}^C$ .

### Relations

- D1.  $Tb(x) =_{df} \exists y tb(x, y)$  ( $x$  is a time boundary)
- D2.  $TE(x) =_{df} Chron(x) \vee Tb(x)$  ( $x$  is a time entity)
- D3.  $comp(x, y) =_{df} Chron(x) \wedge Chron(y) \wedge \exists z (Chron(z) \wedge tpart(x, z) \wedge tpart(y, z))$   
( $x$  and  $y$  are compatible chronoids)
- D4.  $during(x, y) =_{df} Chron(x) \wedge Chron(y) \wedge tppart(x, y) \wedge \neg starts(x, y) \wedge \neg ends(x, y)$   
(Allen's "during" relation (1983))
- D5.  $ends(x, y) =_{df} Chron(x) \wedge Chron(y) \wedge tppart(x, y) \wedge \exists u (ltb(u, x) \wedge ltb(u, y))$   
(Allen's "ends" relation (1983))
- D6.  $meets(x, y) =_{df} Chron(x) \wedge Chron(y) \wedge \exists uv (ltb(u, x) \wedge ftb(v, y) \wedge tcoinc(u, v))$   
(Allen's "meets" relation (1983))
- D7.  $starts(x, y) =_{df} Chron(x) \wedge Chron(y) \wedge tppart(x, y) \wedge \exists u (ftb(u, x) \wedge ftb(u, y))$   
(Allen's "starts" relation (1983))
- D8.  $tb(x, y) =_{df} ftb(x, y) \vee ltb(x, y)$  ( $x$  is a time boundary of  $y$ )
- D9.  $tov(x, y) =_{df} \exists z (tpart(z, x) \wedge tpart(z, y))$  (temporal overlap of chronoids)
- D10.  $tppart(x, y) =_{df} tpart(x, y) \wedge x \neq y$  (proper temporal part-of)

### Functions

- D11.  $ft(x) = y \leftrightarrow_{df} ftb(y, x)$  (functional  $ftb$ : the first time boundary of  $x$  is  $y$ )
- D12.  $lt(x) = y \leftrightarrow_{df} ltb(y, x)$  (functional  $ltb$ : the last time boundary of  $x$  is  $y$ )

## 6.2. Axioms

### Taxonomic Axioms

$T1^{100}$   $TE(x)$  (the domain of discourse covers only time entities)

$T1^{150}$   $\neg\exists x(Chron(x) \wedge Tb(x))$  (chronoid and time boundary are disjoint categories)

$T1^{102}$   $Chron(x) \wedge Chron(y) \rightarrow comp(x, y)$  (every two chronoids are compatible)

$T4^{400-1}$   $tb(x, y) \rightarrow Tb(x) \wedge Chron(y)$  ( $tb$  relates time boundaries with chronoids)

$T4^{402-3}$   $tcoinc(x, y) \rightarrow Tb(x) \wedge Tb(y)$  (coincidence is a relation on time boundaries)

$T4^{404-5}$   $tpart(x, y) \rightarrow Chron(x) \wedge Chron(y)$  (temporal part-of is a relation on chronoids)

### Structure of single relations

$S0^{000}$   $Chron(x) \rightarrow tpart(x, x)$  (reflexivity)

$S0^{001}$   $tpart(x, y) \wedge tpart(y, x) \rightarrow x = y$  (antisymmetry)

$S0^{002}$   $tpart(x, y) \wedge tpart(y, z) \rightarrow tpart(x, z)$  (transitivity)

$A10^{5030}$   $Chron(x) \rightarrow \exists y(starts(x, y))$  (every chronoid has a future extension)

$A11^{5040}$   $Chron(x) \rightarrow \exists y(ends(x, y))$  (every chronoid has a past extension)

$A12^{5051}$   $Chron(x) \rightarrow \exists y(during(y, x))$  (during every chronoid there is another one)

$A13^{5060}$   $Chron(x) \rightarrow \exists y(ftb(y, x))$  (every chronoid has a first boundary)

$A14^{5070}$   $Chron(x) \rightarrow \exists y(ltb(y, x))$  (every chronoid has a last boundary)

$A15^{5100}$   $Chron(x) \wedge ftb(y, x) \wedge ftb(z, x) \rightarrow y = z$  (the first boundary of chronoids is unique)

$A16^{5101}$   $Chron(x) \wedge ltb(y, x) \wedge ltb(z, x) \rightarrow y = z$  (the last boundary of chronoids is unique)

$A17^{5080}$   $Tb(x) \rightarrow \exists y(tb(x, y))$  (every time boundary is a boundary of a chronoid)

$A18^{5500}$   $Tb(x) \rightarrow tcoinc(x, x)$  (reflexivity)

$A19^{5501}$   $tcoinc(x, y) \rightarrow tcoinc(y, x)$  (symmetry)

$A20^{5502}$   $tcoinc(x, y) \wedge tcoinc(y, z) \rightarrow tcoinc(x, z)$  (transitivity)

$A21^{5510}$   $Tb(x) \rightarrow \exists y(x \neq y \wedge tcoinc(x, y))$  (every time boundary coincides with another one)

$A22^{5511}$   $tcoinc(x, y) \wedge tcoinc(x, z) \rightarrow x = y \vee x = z \vee y = z$  (at most two distinct time boundaries coincide)



*Interaction axioms*

A23.<sup>I101</sup>  $tov(x, y) \rightarrow \exists z(tpart(z, x) \wedge tpart(z, y) \wedge \forall u(tpart(u, x) \wedge tpart(u, y) \rightarrow tpart(u, z)))$   
 (two overlapping chronoids have an intersection)

A24.<sup>I100</sup>  $Chron(x) \wedge Chron(y) \wedge \neg tpart(x, y) \rightarrow \exists z(tpart(z, x) \wedge \neg tov(z, y))$   
 (where one chronoid is not a part of another one, there exists a non-overlapping part)

A25.<sup>J003</sup>  $Chron(x) \wedge Chron(y) \wedge tcoinc(ft(x), ft(y)) \wedge tcoinc(lt(x), lt(y)) \rightarrow x = y$   
 (there are no distinct chronoids with coincident boundaries)

A26.<sup>J001</sup>  $tcoinc(x, y) \rightarrow \neg \exists w((ftb(x, w) \wedge ltb(y, w)) \vee (ltb(x, w) \wedge ftb(y, w)))$   
 (coincident boundaries are boundaries of distinct chronoids)

A27.<sup>J002</sup>  $Tb(x) \wedge Tb(y) \wedge \neg tcoinc(x, y) \rightarrow$   
 $\exists z(Chron(z) \wedge ((tcoinc(x, ft(z)) \wedge tcoinc(y, lt(z))) \vee (tcoinc(x, lt(z)) \wedge tcoinc(y, ft(z)))))$   
 (between any two non-coincident time boundaries there is a corresponding chronoid)

A28.<sup>J100</sup>  $tcoinc(x, y) \wedge ftb(x, u) \wedge ftb(y, v) \rightarrow (tpart(u, v) \vee tpart(v, u))$   
 (coincident first boundaries entail parthood)

A29.<sup>J101</sup>  $tcoinc(x, y) \wedge ltb(x, u) \wedge ltb(y, v) \rightarrow (tpart(u, v) \vee tpart(v, u))$   
 (coincident last boundaries entail parthood)

A30.<sup>K003</sup>  $Chron(x) \wedge Chron(y) \wedge \exists u(Chron(u) \wedge ft(u) = ft(y) \wedge tcoinc(lt(u), ft(x))) \wedge$   
 $\exists v(Chron(v) \wedge tcoinc(ft(v), lt(x)) \wedge lt(v) = lt(y)) \rightarrow during(x, y)$   
 ( $x$  is during  $y$  if embedded between two chronoids with appropriate boundaries)

A31.<sup>L002</sup>  $tpart(x, y) \wedge ft(x) \neq ft(y) \rightarrow \exists z(starts(z, y) \wedge tcoinc(lt(z), ft(x)))$   
 (for every part with distinct first boundaries there is a corresponding starts-fragment)

A32.<sup>L003</sup>  $tpart(x, y) \wedge lt(x) \neq lt(y) \rightarrow \exists z(ends(z, y) \wedge tcoinc(ft(z), lt(x)))$   
 (for every part with distinct end boundaries there is a corresponding ends-fragment)

A33.<sup>L000</sup>  $Chron(x) \wedge Chron(y) \wedge meets(x, y) \rightarrow$   
 $\exists z(Chron(z) \wedge ft(x) = ft(z) \wedge lt(y) = lt(z) \wedge \neg \exists u(tpart(u, z) \wedge \neg tov(u, x) \wedge \neg tov(u, y)))$   
 (the sum of meeting chronoids is a chronoid)

A34.<sup>L001</sup>  $tov(x, y) \wedge \exists w(starts(w, x) \wedge \neg tov(w, y)) \rightarrow$   
 $\exists z(Chron(z) \wedge ft(x) = ft(z) \wedge lt(y) = lt(z) \wedge \neg \exists u(tpart(u, z) \wedge \neg tov(u, x) \wedge \neg tov(u, y)))$   
 (the sum of overlapping chronoids is a chronoid)

*6.3. Entailments*

As stated at the beginning of the current section 6,  $\mathcal{BT}^C$  as specified above is not minimal, i.e., not all axioms are independent of each other. For instance, axiom A20 is derivable (see Table 3 below), but it is kept as one of the axioms enforcing coincidence to be an equivalence relation.

Moreover, during the development of the formalization and the proofs of the metalogical results, two further definitions and a number of formulas were considered, the latter as earlier variants of axioms or as useful intermediate steps for proofs.

Table 3 lists interrelations within the overall set of axioms and entailments, additionally verified with SPASS (Weidenbach et al., 2009).

- D13.  $\text{before}(x, y) =_{df} \exists uvz (\text{Chron}(z) \wedge \text{ftb}(u, z) \wedge \text{ltb}(v, z) \wedge \text{tcoinc}(u, x) \wedge \text{tcoinc}(v, y))$   
(time boundary  $x$  is strictly before time boundary  $y$ )
- D14.  $\text{innerb}(x, y) =_{df} \text{Tb}(x) \wedge \text{Chron}(y) \wedge \exists u (\text{tppart}(u, y) \wedge \text{tb}(x, u)) \wedge \neg \text{tb}(x, y)$   
( $x$  is an inner boundary of  $y$ )
- C1.<sup>I000</sup>  $\text{Chron}(x) \wedge \text{ftb}(u, x) \wedge \text{ltb}(v, x) \rightarrow u \neq v$  (the boundaries of a chronoid are different)
- C2.<sup>I020</sup>  $\neg \exists xyz (\text{ftb}(x, y) \wedge \text{ltb}(x, z))$  (boundaries are either only first boundaries or last boundaries)
- C3.<sup>I010</sup>  $\text{tcoinc}(x, y) \wedge \text{ftb}(x, u) \wedge \text{ftb}(y, v) \rightarrow x = y$  (coincident first boundaries of two chronoids are equal)
- C4.<sup>I011</sup>  $\text{tcoinc}(x, y) \wedge \text{ltb}(x, u) \wedge \text{ltb}(y, v) \rightarrow x = y$  (coincident last boundaries of two chronoids are equal)
- C5.<sup>I000</sup>  $\text{Chron}(x) \wedge \text{ftb}(u, x) \wedge \text{ltb}(v, x) \rightarrow \neg \text{tcoinc}(u, v)$  (chronoid boundaries do not coincide)
- C6.<sup>K001</sup>  $\text{starts}(x, y) \rightarrow \exists z (\text{tcoinc}(\text{ft}(z), \text{lt}(x)) \wedge \text{tcoinc}(\text{lt}(z), \text{ft}(y)))$  (starts-complement)
- C7.<sup>K002</sup>  $\text{ends}(x, y) \rightarrow \exists z (\text{tcoinc}(\text{ft}(z), \text{ft}(y)) \wedge \text{tcoinc}(\text{lt}(z), \text{ft}(x)))$  (ends-complement)

Sub theory	Consequence
D1	A17
A5, A18, A19, A22	A20
A26	C5
D1, D8, A18, C5	C1
D7, D8, A4, A15, A19, A20, A21, A22, A26, A28, A31, C1	C3
D5, D8, A4, A15, A19, A20, A21, A22, A26, A29, A32, C1	C4
D1, D8, A5, A21, C3, C4	C2
D1, D7, D5, D8, D10, A4, A14, A18, A19, A22, A25, A32	C6
D1, D7, D5, D8, D10, A4, A13, A18, A19, A22, A25, A31	C7

Table 3

Verified entailment relations in system  $\mathcal{BT}^C$ . The basic order of the rows is by increasing axiom numbers in column ‘‘Consequence’’, but such that formulas used in the proof of a consequence are comprised above that consequence (cf. C5 above C1).

## 7. Metalogical Analyses of $\mathcal{BT}^C$

The development of  $\mathcal{BT}^C$  is grounded on the axiomatic method, established by David Hilbert (1918), and systematically introduced as a basic task of formal ontology (e.g. in Baumann & Herre, 2011, sect. 2), remember also section 1 herein. This method additionally includes the metalogical investigation of the considered theory. Consistency is central in this respect, but not the only issue. In this section we present our metalogical results for  $\mathcal{BT}^C$ .

### 7.1. Linearity of Time

It appears to be intuitive that time is associated with a linear ordering that should be established on the basis of the theory  $\mathcal{BT}^C$ . Such a linear ordering can be defined on the set of equivalence classes of time boundaries. According to the axioms (A18–A22), the coincidence relation as defined on time boundaries is an equivalence relation whose equivalence classes contain exactly two elements. Let  $[x]$  be the equivalence class corresponding to the time boundary  $x$ . We introduce a relation  $<$  (‘before’) on coincidence classes of time boundaries that is defined by the following condition:  $[x] < [y]$  iff there exists a chronoid whose first boundary belongs to  $[x]$  and whose last boundary belongs to  $[y]$ .

**Proposition 1.** *Let  $\mathcal{A}$  be a model of  $\mathcal{BT}^C$ , and let  $[Tb]$  the set of coincidence classes of time boundaries. Then the relation  $<$  defines a dense linear ordering (without least and without greatest element) on  $[Tb]$ .*

*Proof.* The following conditions must be proved.

1. Irreflexivity: For any  $[a] \in [Tb]$ ,  $[a] \not< [a]$ .
2. Asymmetry: For any  $[a], [b] \in [Tb]$ , if  $[a] < [b]$ , then  $[b] \not< [a]$ .
3. Transitivity: For any  $[a], [b], [c] \in [Tb]$ , if  $[a] < [b]$  and  $[b] < [c]$ , then  $[a] < [c]$ .
4. Comparison: For any  $[a], [b] \in [Tb]$  exactly one of the following three conditions has to hold:  $[a] < [b]$ ,  $[b] < [a]$  or  $[a] = [b]$ .
5. Density: For any  $[a], [b] \in [Tb]$  such that  $[a] < [b]$  there exists a  $[c] \in [Tb]$  satisfying the condition  $[a] < [c]$  and  $[c] < [b]$ .
6. Unboundedness: For any  $[a] \in [Tb]$  there are  $[b], [c] \in [Tb]$  such that  $[b] < [a]$  and  $[a] < [c]$ .

(Irreflexivity) In order to show  $[a] \not< [a]$ , assume the contrary,  $[a] < [a]$ . Then by definition of  $<$  there exists a chronoid  $c$  such that  $ft(c) \in [a]$ , and  $lt(c) \in [a]$ , contradicting entailment C5.

(Transitivity) Let  $[a] < [b]$  and  $[b] < [c]$ . We must show that  $[a] < [c]$ . The assumptions imply the existence of two chronoids  $u, v$  such that  $ft(u) \in [a], lt(u) \in [b]$ , and  $ft(v) \in [b], lt(v) \in [c]$ . From this follows that  $[lt(u)] = [ft(v)]$ . Hence, the condition *meets*( $u, v$ ) is satisfied, which by axiom A33 implies the existence of a chronoid  $w$ , such that  $ft(w) \in [a]$  and  $lt(w) \in [c]$ , hence  $[a] < [c]$ .

(Asymmetry) Is implied by irreflexivity and transitivity of  $<$ .

(Comparison) Let  $[a], [b] \in [Tb]$ , and assume that  $[a] \neq [b]$ . We need to prove  $[b] < [a]$  or  $[a] < [b]$ .  $[a] \neq [b]$  entails that for every  $x \in [a], y \in [b]$  we have  $\neg coinc(x, y)$ . By axiom A27 there exists a chronoid  $w$  such that either  $ft(w) \in [x]$  and  $lt(w) \in [y]$ , which yields the condition  $[x] < [y]$ , and hence  $[a] < [b]$ , or  $ft(w) \in [y]$  and  $lt(w) \in [x]$ , which yields  $[y] < [x]$ , and hence  $[b] < [a]$ .

(Density) Let  $[a] < [b]$ . There exists a chronoid  $c$  such that  $ft(c) \in [a], lt(c) \in [b]$ . By axiom A12 there exists a chronoid  $u$  such that the condition *during*( $u, c$ ) holds. Definition D4 together with D5 and D7 entails  $ft(u) \neq ft(c)$  and  $lt(u) \neq lt(c)$ . With axioms A31 and A32 there are a starts- and an ends-fragment of  $c$  that meet  $u$  and thus justify the conditions  $[a] < [ft(u)]$  and  $[ft(u)] < [b]$ .

(Unboundedness) Finally, we prove that the linear ordering ( $[Tb], <$ ) has neither any smallest nor any greatest element. First observe that each chronoid  $v$  has future and past extensions due to axioms A10 and A11. Then the existence of complements for starts- and end-fragments according to entailments C6 and C7 in combination with the definition of  $<$  ensures that the boundaries of those extensions are appropriately positioned, i.e., for every future extension  $w$  of  $v$  follows  $[lt(v)] < [lt(w)]$ , analogously, for every past extension  $u$  of  $v$  holds  $[ft(u)] < [ft(v)]$ . For the reasons that (i) this argumentation applies to every chronoid (including the extensions mentioned), (ii) all chronoids are compatible by A3, and (iii) time boundaries depend on chronoids by A17, there cannot be any smallest or greatest element of  $<$ .  $\square$

**Corollary 1.** *If  $[Tb]$  is a countable set, then the structure ( $[Tb], <$ ) is isomorphic to the linear ordering of the rational numbers.*

*Proof.* By a theorem of Georg Cantor any two countable dense linear orderings without smallest and greatest element are isomorphic (Enderton, 1993, p. 149).  $\square$

## 7.2. Consistency, Completeness and Decidability of the Theory $\mathcal{BT}^C$

A proof of (relative<sup>20</sup>) consistency of  $\mathcal{BT}^C$  can be achieved by reduction to the monadic second order theory of linear orderings. Let  $\lambda$  be the order type of the real numbers  $\mathbb{R}$ . We construct a new linear ordering  $\mathcal{M} = (M, \leq)$ , the type of which is denoted by  $\lambda(2)$ , by taking the linear ordered sum over  $\mathbb{R}$  of linear orderings of type **2**.

For an intuition on that sum, imagine the line of the reals on which each number  $\alpha$  has been cut into two halves, which themselves are ordered (i.e., one half precedes the other, which is an order of type **2**). Following the usual “less than” order of the reals (which has type  $\lambda$ ), all those distinct orders of two halves each are combined into a single ordering (of type  $\lambda(2)$ ) over the set of all those halves. More precisely, the linear ordering  $\mathcal{M} = (M, \leq)$  is constructed as follows. Let  $\mathcal{D}_\alpha = (D_\alpha, \leq_\alpha)$  be a linear ordering for every  $\alpha \in \mathbb{R}$ , such that  $\mathcal{D}_\alpha$  is isomorphic to  $(\{0, 1\}, \leq^{\mathbb{R}})$ ,<sup>21</sup> and furthermore,  $\mathcal{D}_\alpha \cap \mathcal{D}_\beta = \emptyset$  for every  $\alpha \neq \beta$ . Then  $\mathcal{M} = (M, \leq)$  is defined as follows:  $M = \bigcup_{\alpha \in \mathbb{R}} D_\alpha$ , and for any  $a, b \in M$ :  $a \leq b$  if and only if (i) there exists an  $\alpha \in \mathbb{R}$  such that  $a, b \in D_\alpha$  and  $a \leq_\alpha b$  or (ii) there exist  $\alpha, \beta \in \mathbb{R}$  such that  $\alpha <^{\mathbb{R}} \beta$  and  $a \in D_\alpha$ ,  $b \in D_\beta$ .

Within the monadic second order theory of  $\mathcal{M}$  we define the relations  $Chron(x)$ ,  $ftb(x, y)$ ,  $ltb(x, y)$ ,  $tcoinc(x, y)$ , and  $tpart(x, y)$  as follows.  $Chron(x)$  if and only if  $x$  is an interval  $[a, b]$  over  $M$  whose first element  $a$  has an immediate predecessor, and whose last element  $b$  has an immediate successor. The first and the last boundary of a chronoid is determined by the corresponding elements of the associated interval. Any boundary coincides with itself and any two distinct boundaries coincide if one is an immediate successor of the other. Eventually, temporal part-of corresponds to the subinterval relation, restricted to intervals that satisfy the conditions of a chronoid. In this way we get a new structure  $\mathcal{A}$  for which it follows that  $\mathcal{A}$  satisfies all axioms of  $\mathcal{BT}^C$ .<sup>22</sup>

**Proposition 2.** *The theory  $\mathcal{BT}^C$  is consistent.*

*Proof.* Given the considerations above the proposition, it remains to be shown that the axioms A1–A34 are true in the structure  $\mathcal{A}$ . For most of the axioms these proofs are straightforward, based on general mathematical properties of intervals and linear orderings. Therefore, here we present the interesting cases and only some of the simpler ones.

C2 states that no time boundary is a first boundary of one chronoid and also a last time boundary of the same or another chronoid. Although C2 is actually a consequence of a large set of axioms, cf. Table 3, it is useful to observe that the following reformulation is satisfied in  $\mathcal{A}$ : the set of time boundaries, i.e.,  $M$  in  $\mathcal{A}$ , is partitioned into a set of first time boundaries and a set of last time boundaries. This is a straightforward consequence of the chosen linear ordered sum, where each element either has an immediate predecessor or an immediate successor. The former are first time boundaries (only), the latter are last time boundaries (only).

A3 requires mutual compatibility of all chronoids. If  $u, v$  are two chronoids in  $\mathcal{A}$ , then there are elements  $a, b, c, d$  such that  $u = [a, b]$  and  $v = [c, d]$ . There is an interval  $w$  such that  $[a, b] \subseteq w$  and  $[c, d] \subseteq w$ , namely  $w = [\min(\{a, c\}), \max(\{b, d\})]$ . This is a chronoid because  $a$  and  $c$  are first time boundaries (of  $u$  and  $v$ , resp., and thus in general, cf. the observation w.r.t. C2 above), whereas  $b$  and  $d$  are last time boundaries.  $u$  and  $v$  are subintervals of  $w$ , because  $\min(\{a, c\}) \leq a < b \leq \max(\{b, d\})$  and  $\min(\{a, c\}) \leq c < d \leq \max(\{b, d\})$ .

Due to the fact that the subinterval relation is a partial order on intervals we deduce that  $tpart$  is a partial order on  $Chron$ , i.e., axioms A7, A8 and A9 are satisfied in  $\mathcal{A}$ .

Unboundedness and density of the reals are the main reasons for the fulfillment of axioms A10, A11, and A12 in  $\mathcal{A}$ , i.e., any chronoid has a future/past extension as well as proper subintervals.

<sup>20</sup>as will be clear from below, see footnote 22.

<sup>21</sup> $\leq^{\mathbb{R}}$  denotes the usual “less than” ordering on the reals,  $<^{\mathbb{R}}$  below its strict variant.

<sup>22</sup>The consistency proof is not an absolute one. We construct a structure  $\mathcal{A}$  the existence of which must be assured by another theory. It is obvious that the existence of  $\mathcal{A}$  can be established on the basis of set theory, say ZFC (Zermelo-Fraenkel with the axiom of choice). Hence, the theory  $\mathcal{BT}^C$  is relatively consistent with respect to ZFC.

A15 declares the first boundary of each chronoid to be uniquely determined. Due to  $[a, b] = [c, d]$  iff  $a = c$  and  $b = d$ , uniqueness of the first boundary is an immediate consequence of the definitions of chronoids as intervals  $[a, b]$  over  $M$  and of the relation  $ftb$  as above. (A16 is proved analogously.)

Due to the construction of  $\mathcal{A}$ , any element possesses either exactly one predecessor or exactly one successor, and  $coinc$  of two boundaries is given if they are identical or one is an immediate successor of the other. Consequently, the interpretation of  $coinc$  in  $\mathcal{A}$  is an equivalence relation on  $Tb$  in  $\mathcal{A}$ , i.e., axioms A18, A19 and A20 are satisfied.

A21 says that for every time boundary  $x$  there exists a time boundary  $y$  such that  $x$  and  $y$  are distinct and coincide. Let  $x$  be a time boundary. By definition of  $\mathcal{A}$  there exists a chronoid  $u$  such that, w.l.o.g.,  $x = ft(u)$ . Since  $u$  satisfies the definition of the predicate  $Chron$ ,  $x$  must possess an immediate predecessor  $y$ , hence  $x \neq y$ , while by definition  $x$  and  $y$  coincide.

A22 limits the number of coinciding time boundaries to at most two. By the formation of the linear ordered sum, especially using type 2, there are exactly only pairs of elements that are immediate successors of each other. Since the latter is the definition for the predicate  $coinc$ , this directly leads to coincidence classes of exactly two elements. (At once this proves the existence of a distinct, but coincident time boundary for each time boundary, required in A21.)

A25 states, in contraposition, that two distinct chronoids do not possess coincident pairs of first and last time boundaries. Accordingly, let  $[a, b]$  and  $[c, d]$  be chronoids in  $\mathcal{A}$  and assume  $coinc(a, c)$ . It follows that  $a = c$ , because both must have an immediate  $\leq$ -predecessor by definition of  $Chron$ , and as seen for A22, coincidence classes have exactly two elements in  $\mathcal{A}$ . Analogously  $b = d$  holds. Therefore,  $[a, b] = [c, d]$  due to the same equivalence for intervals used for A15 above, i.e., there are no distinct chronoids with coincident boundaries.  $\square$

Further metalogical results on  $\mathcal{BT}^C$  concern its completeness and decidability. The latter means that there is an effective method to decide whether a sentence is a consequence of  $\mathcal{BT}^C$  (cf. e.g. Enderton, 1993, sect. 2, for these notions).

**Proposition 3.** *The theory  $\mathcal{BT}^C$  is complete and decidable.*

The proof relies on showing that  $\mathcal{BT}^C$  is an  $\omega$ -categorical theory, i.e., any two countably infinite models of  $\mathcal{BT}^C$  are isomorphic. We define a corresponding isomorphism between two arbitrary countably infinite models of  $\mathcal{BT}^C$ , starting from an isomorphism between their sets of coincidence classes. The latter is justified by Proposition 1 and Corollary 1, where the latter basically refers to Cantor's theorem that any two countable dense linear orderings are isomorphic (Enderton, 1993, p. 149).  $\omega$ -categoricity of  $\mathcal{BT}^C$  entails its completeness. Eventually, completeness and axiomatizability of a theory yield its decidability (Enderton, 1993, p. 147).

*Proof.* We show that the theory  $\mathcal{BT}^C$  is  $\omega$ -categorical, which entails completeness and, given axiomatizability, decidability.

Let  $\mathcal{A}, \mathcal{B}$  two arbitrary countably infinite models of  $\mathcal{BT}^C$ . We consider two structures  $([Tb^{\mathcal{A}}], <)$  and  $([Tb^{\mathcal{B}}], <)$ ,<sup>23</sup> where  $<$  refers to the 'before' relation among coincidence classes of time boundaries introduced in section 7.1. By corollary 1 these structures are isomorphic and we fix an isomorphism  $\delta$  from  $([Tb^{\mathcal{A}}], <)$  onto  $([Tb^{\mathcal{B}}], <)$ .  $\delta$  is used to construct an isomorphism  $\alpha$  from  $\mathcal{A} = (U^{\mathcal{A}}, Tb^{\mathcal{A}}, Chron^{\mathcal{A}}, ftb, ltb, coinc, tpart)$  onto  $\mathcal{B} = (U^{\mathcal{B}}, Tb^{\mathcal{B}}, Chron^{\mathcal{B}}, ftb, ltb, coinc, tpart)$ .<sup>23</sup> Note that the axioms of  $\mathcal{BT}^C$  ensure that the universes  $U^{\mathcal{A}}$  and  $U^{\mathcal{B}}$ , respectively, are disjoint unions of the corresponding pairs of predicates  $Tb$  and  $Chron$ .

In the first step we introduce the *characteristic* of a boundary  $x$  within  $\mathcal{A}$  resp.  $\mathcal{B}$  as follows:  $ch_{\mathcal{A}}(x) = f$ , if  $x$  is the first boundary of a chronoid, and  $ch_{\mathcal{A}}(x) = l$  if  $x$  is the last boundary of a chronoid. Note that the characteristic of a time boundary is uniquely determined, cf. entailment C2 in section 6.3.

<sup>23</sup>For readability, we omit structure indices at binary relations since these will be clear from the typing of their arguments by means of indexed unary predicates.

Next we specify a function  $\beta$  between the sets  $Tb^A$  and  $Tb^B$  by  $\beta(x) = y$  iff  $\delta([x]) = [y]$  and  $ch_A(x) = ch_B(y)$ . It is easy to show that  $\beta$  is a bijection between the sets  $Tb^A, Tb^B$  which preserves the characteristics of the boundaries.

The function  $\beta$  is extended to a bijective function  $\alpha : U^A \rightarrow U^B$ , where it remains to define the function  $\alpha$  for the set  $Chron^A$ . Let be  $c \in Chron^A$  and for  $x, y \in Tb^A : ftb(x, c)$  and  $ltb(y, c)$ , then by the axioms of  $\mathcal{BT}^C$  it follows that  $[x] < [y]$ , and hence  $\delta([x]) < \delta([y])$ . Let  $\delta([x]) = U$ , and  $\delta([y]) = V$ .  $\mathcal{BT}^C$  entails the uniquely determined existence of a chronoid  $d$  and time boundaries  $u, v$  in  $\mathcal{B}$  such that  $u \in U$  with  $ftb(u, d)$  and  $v \in V$  with  $ltb(v, d)$ , cf. e.g. A15, A16, and A25. Accordingly, we stipulate  $\alpha(c) = d$ .

It remains to be shown that  $\alpha$  is an isomorphism from  $\mathcal{A}$  onto  $\mathcal{B}$ . Obviously,  $\alpha$  is an injective function from  $Tb^A \cup Chron^A$  into  $Tb^B \cup Chron^B$ . To see that  $\alpha$  is surjective, note first that  $\beta$  is bijective from  $Tb^A$  onto  $Tb^B$ , based on its definition, cf. above. We prove that  $\alpha$  is surjective for the set  $Chron^B$ . Let  $d$  be a chronoid of  $\mathcal{B}$ , for which there must be  $u, v \in Tb^B$  with  $ftb(u, d)$  and  $ltb(v, d)$ . We form the classes  $\delta^{-1}([u]) = X$  and  $\delta^{-1}([v]) = Y$ . The axioms of  $\mathcal{BT}^C$  imply the existence of a uniquely determined chronoid  $c$  and time boundaries  $x, y$  such that  $x \in X$  with  $ftb(x, c) \in X$  and  $y \in Y$  with  $ltb(y, c) \in Y$ . By definition of  $\alpha$  this implies  $\alpha(c) = d$ .

Finally,  $\alpha$  must preserve the relations  $Chron(x), Tb(x), ftb(x, y), ltb(x, y), tcoinc(x, y)$ , and  $tpart(x, y)$ . The proof of these homomorphism conditions is mainly straightforward, though cumbersome. It is immediately clear that  $\alpha$  is compatible with the relations  $Chron(x)$  and  $Tb(x)$ , as well as  $tcoinc$ . In the sequel we restrict the proof to the relation  $ftb(x, y)$ ; the compatibility condition for the relation  $ltb(x, y)$  is proved analogously. The case of  $tpart(x, y)$  is omitted.

Homomorphism in the case of  $ftb$  means  $ftb(x, c) \leftrightarrow ftb(\alpha(x), \alpha(c))$  for all  $x \in Tb^A$  and  $c \in Chron^A$ .

( $\rightarrow$ ). Let  $ftb(x, c)$ , then  $ch_A(x) = f$ , and hence  $ch_B(\alpha(x)) = f$ , because of  $\alpha(x) = \beta(x)$  (for time boundaries) and of  $ch_A(x) = ch_B(\beta(x))$ . By the definition of  $\alpha$  the chronoid  $\alpha(c) = d$  with its first time boundary  $u$ ,  $ftb(u, d)$ , has the property  $u \in \delta([x])$ . This implies  $u = \beta(x)$ , because  $x$  and  $\beta(x)$  have the same characteristic.

( $\leftarrow$ ). This direction is similar to the previous one. □

### 7.3. Relationship with Established Time Theories

Remembering the available work on time, cf. section 2, it is of interest to relate  $\mathcal{BT}^C$  to other axiomatizations. It is rather straightforward to show that  $\mathcal{BT}^C$  covers  $\mathcal{IP}_{dense}$  (Vila, 1994, 2005; Vila & Schwalb, 1996) (and thus  $\mathcal{AH}$ , the well-known theory of Allen and Hayes, as well, see section 2) in the following sense.

**Proposition 4.** *The point-interval theory  $\mathcal{IP}_{dense}$  is interpretable in  $\mathcal{BT}^C$ .*

*Theory Interpretation in Logic and Central Proof Ideas* Prior to introducing  $\mathcal{IP}_{dense}$  more precisely in order to prove proposition 4 in some detail, a coarse-grained view on this result and its logical setup shall lay out some intuition.

In mathematical logic, interpreting a theory  $S$  into another theory  $T$  requires a translation function  $\tau$  of (roughly<sup>24</sup>) the signature of  $S$  into the language of  $T$ , where  $T$  must satisfy a set of so-called closure axioms  $CA_\tau$  (as determined by  $\tau$ ),  $T \models CA_\tau$ .  $S$  is called *interpretable* in  $T$ , if such  $\tau$  exists and the result of translating  $S$  is already entailed by  $T$ , as well, i.e.,  $T \models CA_\tau \cup \tau(S)$ . Put differently,  $S$  is interpretable in  $T$  if it is “preserved” within  $T$  by means of an appropriate “understanding” or “reflection” of the signature of  $S$  in terms of the language of  $T$ . We generally refer to (Rautenberg, 2010, sect. 6.6) and (Enderton, 1993, sect. 2.7) for the mathematical background, which follow slightly different, yet equivalent approaches of capturing those translations formally. Notably, (Grüninger, Hahmann, Hashemi, Ong, & Ozgovde, 2012, sect. 3.2) recapitulates the definition of (an earlier edition of) (Enderton, 1993) and employs it in connection with establishing ontology repositories. Below we basically adopt the definition

<sup>24</sup>In addition to the non-logical symbols of  $S$ , quantification in  $S$  needs to be relativized to quantification within  $T$  (cf. e.g. Rautenberg, 2010, p. 258). This can be realized by a formula with one free variable or by defining an additional unary predicate, neither occurring in  $S$  nor  $T$ .

in (Rautenberg, 2010, sect. 6.6), simplified to the specific case where it suffices to specify a set  $\Delta$  of explicit definitions for symbols in  $S$  and to prove  $T \cup \Delta \models S$ .

The proof of proposition 4 relies on a quite natural translation of  $\mathcal{IP}_{\text{dense}}$  vocabulary into (the language of)  $\mathcal{BT}^C$ .  $\mathcal{IP}_{\text{dense}}$  is based on a distinction between *instants* and *periods*, and contains three primitive relations: *before* is a strict linear order on instants, whereas *begin* and *end* relate instants to those periods of which the former are their initial and terminal instants. The interpretation of this vocabulary into  $\mathcal{BT}^C$  associates instants <sup>$\mathcal{IP}$</sup>  with time boundaries <sup>$\mathcal{BT}^C$</sup> , and periods <sup>$\mathcal{IP}$</sup>  with chronoids <sup>$\mathcal{BT}^C$</sup> . This linkage is in agreement with mapping *before* <sup>$\mathcal{IP}$</sup> ( $x, y$ ) between two instants  $x$  and  $y$  to the formula  $\exists uvz(\text{Chron}(z) \wedge \text{ftb}(u, z) \wedge \text{lfb}(v, z) \wedge \text{tcoinc}(u, x) \wedge \text{tcoinc}(v, y))$  (cf. the tantamount informal definition of the ‘before’ relation  $<$  in section 7.1), and *begin* <sup>$\mathcal{IP}$</sup> ( $x, y$ ) and *end* <sup>$\mathcal{IP}$</sup> ( $x, y$ ) to the formulas  $\exists z(\text{tcoinc}(x, z) \wedge \text{ftb}(z, y))$  and  $\exists z(\text{tcoinc}(x, z) \wedge \text{lfb}(z, y))$ , respectively. Observing the occurrence of temporal coincidence in all formulas reflecting these three  $\mathcal{IP}_{\text{dense}}$  relations indicates that coincidence requires some care in the interpretation. In particular and unconventionally, equality of instants <sup>$\mathcal{IP}$</sup>  must be interpreted by *tcoinc* <sup>$\mathcal{BT}^C$</sup> . This interpretation ensures that each instant <sup>$\mathcal{IP}$</sup>  is aligned with a unique time boundary <sup>$\mathcal{BT}^C$</sup> , but such that distinct instants <sup>$\mathcal{IP}$</sup>  yield non-coincident time boundaries <sup>$\mathcal{BT}^C$</sup> . Importantly and although all of this nicely matches the intuitions behind the two theories, theory interpretation is a formal tool for analyzing theory interrelations. It cannot necessarily be understood to provide ontological insights across the theories under consideration.

*Proof of Interpretability of  $\mathcal{IP}$  into the Theory  $\mathcal{BT}^C$*  In preparation of the proof of Proposition 4, let us first introduce the theory  $\mathcal{IP}_{\text{dense}}$  formally, based on (Vila, 2005, sect. 1.7.2). Therein, this theory is formulated in two-sorted FOL with one sort for *instants* ( $\mathcal{I}$ ) and one for *periods* ( $\mathcal{P}$ ). Thus, we have the three primitive binary relations of  $\mathcal{IP}_{\text{dense}}$  (besides identity): a strict linear order  $< \subseteq \mathcal{I} \times \mathcal{I}$  as *before* <sup>$\mathcal{IP}$</sup>  and two cross-sortal relations *begin*, *end*  $\subseteq \mathcal{I} \times \mathcal{P}$  as explained above.

Aiming at a clear separation of transitioning from sorted to unsorted FOL on the one hand, and the actual interpretation function in the proof on the other hand, we specify the axioms of  $\mathcal{IP}_{\text{dense}}$  in terms of classical FOL. For this purpose, we replace sorts with unary predicates, namely  $I(x)$  for instants and  $P(x)$  for periods, relativize the formulas in (Vila, 2005, sect. 1.7.2) correspondingly, and augment the theory with axiom IP0 to account for the sort constraints, namely that both sorts form a partitioning of the domain of discourse and are not empty. The symbol  $=_{\text{IP}}$  denotes standard identity in the context of  $\mathcal{IP}_{\text{dense}}$ . To maintain a clearer connection with (Vila, 2005, sect. 1.7.2), we follow its presentation by using variable names  $i, i', i''$  for instants and  $p, p'$  for periods on all occurrences of a single sort. The ordering of axioms is maintained, as well, except for density (IP7) being inserted in the block of axioms concerned with instants only. All of that yields the following as theory  $\mathcal{IP}_{\text{dense}}$  in FOL (without sorts).

$$\text{IP0. } (I(x) \vee P(x)) \wedge \neg \exists x (I(x) \wedge P(x)) \wedge \exists x I(x) \wedge \exists x P(x) \quad (\text{sort constraints})$$

$$\text{IP1. } I(i) \rightarrow \neg(i < i) \quad (\text{irreflexivity})$$

$$\text{IP2. } I(i) \wedge I(i') \wedge i < i' \rightarrow \neg(i' < i) \quad (\text{asymmetry})$$

$$\text{IP3. } I(i) \wedge I(i') \wedge I(i'') \wedge i < i' \wedge i' < i'' \rightarrow i < i'' \quad (\text{transitivity})$$

$$\text{IP4. } I(i) \wedge I(i') \rightarrow (i < i' \vee i' < i \vee i =_{\text{IP}} i') \quad (\text{linearity})$$

$$\text{IP5. } I(i) \rightarrow \exists i' (I(i') \wedge i' < i) \quad (\text{unboundedness, in left argument})$$

$$\text{IP6. } I(i) \rightarrow \exists i' (I(i') \wedge i < i') \quad (\text{unboundedness, in right argument})$$

$$\text{IP7. } I(i) \wedge I(i') \wedge i < i' \rightarrow \exists i'' (I(i'') \wedge i < i'' < i') \quad (\text{density})$$

- IP8.  $P(p) \wedge I(i) \wedge I(i') \wedge \text{begin}(i, p) \wedge \text{end}(i', p) \rightarrow i < i'$  (ordering period endpoints)
- IP9.  $P(p) \rightarrow \exists i (I(i) \wedge \text{begin}(i, p))$  (existence of begin)
- IP10.  $P(p) \rightarrow \exists i (I(i) \wedge \text{end}(i, p))$  (existence of end)
- IP11.  $P(p) \wedge I(i) \wedge I(i') \wedge \text{begin}(i, p) \wedge \text{begin}(i', p) \rightarrow i =_{\text{IP}} i'$  (uniqueness of begin)
- IP12.  $P(p) \wedge I(i) \wedge I(i') \wedge \text{end}(i, p) \wedge \text{end}(i', p) \rightarrow i =_{\text{IP}} i'$  (uniqueness of end)
- IP13.  $I(i) \wedge I(i') \wedge i < i' \rightarrow \exists p (P(p) \wedge \text{begin}(i, p) \wedge \text{end}(i', p))$   
(existence of a period between two ordered instants)
- IP14.  $P(p) \wedge P(p') \wedge I(i) \wedge I(i') \wedge \text{begin}(i, p) \wedge \text{end}(i', p) \wedge \text{begin}(i, p') \wedge \text{end}(i', p') \rightarrow p =_{\text{IP}} p'$   
(uniqueness of the period between two instants)

*Proof.* In accordance with (Rautenberg, 2010, sect. 6.6), cf. also (Grüniger & Ong, 2011, sect. II), we will now specify an interpretation of  $\mathcal{IP}_{\text{dense}}$  into  $\mathcal{BT}^{\mathcal{C}}$  by providing the set  $\Delta$  of explicit definitions ID1–ID6 for all  $\mathcal{IP}_{\text{dense}}$  predicates, where the definientes are limited to the language of  $\mathcal{BT}^{\mathcal{C}}$ . Note that the interpretation of identity accommodates a special case for instants, relaxing their identity in  $\mathcal{IP}_{\text{dense}}$  to temporal coincidence in  $\mathcal{BT}^{\mathcal{C}}$ .

- ID1.  $I(x) =_{\text{df}} \text{Tb}(x)$
- ID2.  $P(x) =_{\text{df}} \text{Chron}(x)$
- ID3.  $x < y =_{\text{df}} \exists uvz (\text{Chron}(z) \wedge \text{ftb}(u, z) \wedge \text{lfb}(v, z) \wedge \text{tcoinc}(u, x) \wedge \text{tcoinc}(v, y))$
- ID4.  $\text{begin}(x, y) =_{\text{df}} \exists z (\text{tcoinc}(x, z) \wedge \text{ftb}(z, y))$
- ID5.  $\text{end}(x, y) =_{\text{df}} \exists z (\text{tcoinc}(x, z) \wedge \text{lfb}(z, y))$
- ID6.  $x =_{\text{IP}} y =_{\text{df}} x = y \vee (\text{Tb}(x) \wedge \text{Tb}(y) \wedge \text{tcoinc}(x, y))$

In order to prove proposition 4, now it suffices to show  $\mathcal{BT}^{\mathcal{C}} \cup \Delta \models \mathcal{IP}_{\text{dense}}$ . Observe that the interpretation equates the domains of discourse of  $\mathcal{IP}_{\text{dense}}$  and  $\mathcal{BT}^{\mathcal{C}}$  models, since it dispenses with any domain restriction. Moreover, there are neither function nor individual constant symbols in  $\mathcal{IP}_{\text{dense}}$ . Accordingly, no additional closure axioms (Rautenberg, 2010, p. 258–259) need to be proved from  $\mathcal{BT}^{\mathcal{C}} \cup \Delta$ .<sup>25</sup> Subsequently, we provide coarse-grained arguments for the entailment of  $\mathcal{IP}_{\text{dense}}$  and only refer to axioms of major relevance, e.g. without resolving all definitions and argument type constraints of relations that are required for verifying these proofs in a theorem prover.

1. The reformulation of the sort constraints in IP0 via  $\Delta$  into

$$(\text{Tb}(x) \vee \text{Chron}(x)) \wedge \neg \exists x (\text{Tb}(x) \wedge \text{Chron}(x)) \wedge \exists x \text{Tb}(x) \wedge \exists x \text{Chron}(x)$$

can be easily derived from the “partitioning axioms” for chronoids and time boundaries in  $\mathcal{BT}^{\mathcal{C}}$  (A1, A2) and, starting from a non-empty universe, axioms that require mutual existence of chronoids and time boundaries such as A13 and A17.

<sup>25</sup>But note that the sort constraints in IP0 are similar in spirit to some of the closure axioms (Rautenberg, 2010, p. 258–259).



2. The properties of  $<$  as an unbounded dense linear order (IP1-IP7) should be accepted in the light of proposition 1 and its proof in section 7.1, in combination with basically equivalent definitions of the relation  $<$  (‘before’) in that section and  $<$  in the present context.
3. Assuming the preconditions in IP8 together with the corresponding definitions, its consequence results from a mere application of ID3, the definition of  $<$ .
4. Existence of begin and end of a period (IP9, IP10) corresponds directly to the existence of first and last time boundaries (A13, A14), with reflexivity of temporal coincidence (A18) closing the technical gap in definitions ID4 and ID5.
5. “Uniqueness” of begin and end of a period (IP11, IP12) derives directly from the uniqueness of first and last time boundaries of chronoids, axioms A15, A16. Temporal coincidence in ID4 and ID5 is not problematic, since the consequents of IP11 and IP12 under the interpretation do no longer enforce identity (within  $\mathcal{BT}^C$ ), but only temporal coincidence in the case of time boundaries. Notably, uniqueness applies to equivalence classes of *tcoinc* (not available within  $\mathcal{BT}^C$ , but from the metatheoretic perspective, cf. section 7.1).
6. Just the definitions of  $<$ , *begin*, and *end* (ID3-ID5) entail the existence of a period between two instants that are ordered by  $<$ .
7. Uniqueness of a period between two instants (IP14) is a consequence of excluding distinct chronoids with coinciding pairs of first and last time boundaries, A25 in  $\mathcal{BT}^C$ .

□

## 8. $\mathcal{BT}^R$ – Towards an Ontology of Time Regions

$\mathcal{BT}^C$  as presented in the previous sections focuses on chronoids and time boundaries. Notice that all chronoids are understood to be connected wholes, i.e., without any temporal gaps. In this section we consider the domain of time regions, where a time region is not necessarily connected, in contrast to a chronoid.

### 8.1. *Motivating Scenarios*

There are situations in reality the modeling of which may use time regions. Let us consider the course of a disease, for example, of malaria. One may be interested only in those time intervals in the course of malaria of a patient during which something happens. In general, such a process exhibits a certain pattern, typically including active phases and periods of rest. For instance, in the case of malaria, one may observe hot stages (intervals of raising and then remittent fever) alternating with stationary phases of no fever. Moreover, at the social level many processes proceed with “temporal gaps”, such as court cases and lecture series. The representation of corresponding information refers to underlying sequences of non-overlapping chronoids during which the active phases of a process occur. Such sequences of non-overlapping chronoids are subsequently called time regions. They play a significant role in methods of temporal abstraction, i.e., abstracting higher-level concepts from time-stamped data (see Shahar, 1994).

### 8.2. *Conceptual Outline*

In this and the next two sections we sketch an ontology of time regions, termed  $\mathcal{BT}^R$ , which is intended as an extension of the domain of chronoids axiomatized in  $\mathcal{BT}^C$ . Analogously to Figure 3 in section 4.1, Figure 4 presents the categories and relations for this enhanced ontology of time.

Each *time region* is understood as the mereological sum of a number of *chronoids* (as known from  $\mathcal{BT}^C$ ) which are called its constituting components. Vice versa, chronoids can now be understood as specific time regions, namely exactly as the connected time regions. As in  $\mathcal{BT}^C$ , any chronoid (and thus any constituent component of a time region) possesses two *time boundaries*, its respective first and last one, each uniquely determined. *Time boundary regions* parallel the notion of time boundaries, but at the

---

FL-Änderung: “sum of a finite number” abgeschwächt zu “sum of a number of”, entsprechend Diskussion mit Ringo.

---

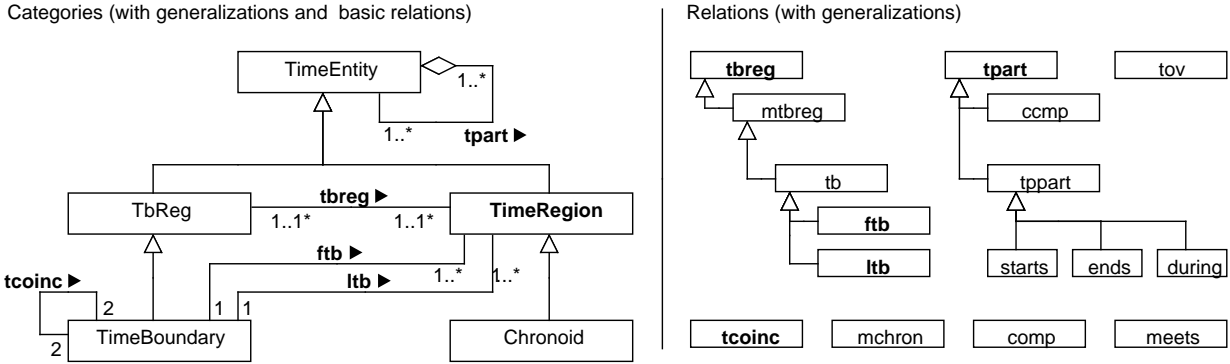

Figure 4. Categories and relations of the time theory  $\mathcal{BT}^{\mathcal{R}}$  of GFO. Boldface signifies primitives.

level of time regions. They arise as mereological sums of the time boundaries of constituting components of time regions. Accordingly, each time region  $R$  has a greatest time boundary region (the sum of all time boundaries of all of  $R$ 's components), and any time boundary region of  $R$  is a part of that greatest time boundary region, where time boundaries constitute minimal parts (or atoms).

A number of basic relations connect instances of time regions and time boundary regions, either within the same category or across the two. *Parthood* in  $\mathcal{BT}^{\mathcal{R}}$  has its intuitive meaning, but more generally than in  $\mathcal{BT}^{\mathcal{C}}$ , it applies separately to time regions and time boundary regions, i.e., both arguments must be of the same kind. The *coincidence relation* *tcoinc* continues to be applicable only to time boundaries. A notion of generalized temporal coincidence can be defined on this basis such that its arguments can be arbitrary time boundary regions. For linking time regions with their time boundary regions, a general relation of being a *time boundary region* of a time region, *tbreg*, is introduced. In addition, the relational notions of being the *first* and *last boundary* are extended to time regions and likewise serve as primitive relations, based on the following intuitions. We assume that any time region  $r$  is a temporal part of a chronoid, and that there is a (mereologically) least chronoid  $c$  containing  $r$  as its part. The first boundary of  $c$  is then taken to be the first boundary of  $r$  (analogously for the last boundary). An alternative view for the first and last boundary of  $r$  is the adoption of the first boundary of the first constituting component for the latter. While both intuitions can guide axiom development, it is subject to using  $\mathcal{BT}^{\mathcal{R}}$  after its establishment below to prove the equivalence of these connections.

## 9. Axiomatization of the Ontology $\mathcal{BT}^{\mathcal{R}}$

In general, the current axiomatization is mainly derived from  $\mathcal{BT}^{\mathcal{C}}$  in section 6, by adapting its definitions and axioms to the more general categories of time regions and time boundary regions, where this appeared appropriate. New axioms that were not derived in this way are marked with  $^+$  in section 9.2. Moreover, we highlight interesting deviations and additions in the respective subsections.

### 9.1. Signature and Definitions

The formal ontology of time regions is based on the category of time regions and the five relations discussed in section 8.2, here introduced as predicates in Table 4. These notions are taken as primitives in  $\mathcal{BT}^{\mathcal{R}}$ , whereas the categories of chronoids (via the notion of connectedness), time boundary regions and time boundaries become definable. A number of further predicates (and functions, for the purpose of readability) are defined in addition in D1–D19. Regarding defined symbols and their definitions, we follow the same approach as in the case of  $\mathcal{BT}^{\mathcal{C}}$ , explained in detail in section 6.1. In summary, defined symbols are introduced together with their definitions below and Table 5 shows their dependencies.<sup>26</sup>

<sup>26</sup>Definitions in lower levels in Table 5 use only symbols from levels strictly above, i.e., the dependencies are acyclic.

Atomic Formula	Intended Reading
B1. $TReg(x)$	$x$ is a time region
B2. $ftb(x, y)$	$x$ is the first boundary of $y$
B3. $ltb(x, y)$	$x$ is the last boundary of $y$
B4. $tbreg(x, y)$	$x$ is time boundary region of $y$
B5. $tcoinc(x, y)$	$x$ and $y$ are coincident
B6. $tpart(x, y)$	$x$ is a temporal part of $y$

Table 4  
Basic signature of  $\mathcal{BT}^{\mathcal{R}}$ .

Definition	Definiens Symbols	Clustered
$TbReg$	D4	B4
$tov$	D15	B6
$tppart$	D16	B6
$ft$	D17	B2
$lt$	D18	B3
$tb$	D14	B2, B3
$meets$	D11	B1, B2, B3, B5
$TE$	D5	B1, D4
$mtbreg$	D12	B4, D16
$Tb$	D3	D12
$Conn$	D2	B1, B5, D12, D15
$Chron$	D1	D2
$comp$	D7	B1, B6, D1
$mchron$	D10	B1, B6, D1
$ccmp$	D6	B1, B6, D1, D2
$mchr$	D19	D10
$ends$	D9	B1, B3, B6, D16, D19
$starts$	D13	B1, B2, B6, D16, D19
$during$	D8	B1, D9, D13, D15, D16

Table 5  
Defined signature with dependencies in  $\mathcal{BT}^{\mathcal{R}}$ .

The following signature elements are added to those available in  $\mathcal{BT}^{\mathcal{C}}$ :  $Conn$  for connected time regions (without any “gaps” between their components),  $TbReg$  capturing time boundary regions as such,  $ccmp$  linking maximal connected components to time regions,  $mchron$  (as function:  $mchr$ ), which relates a time region to its minimal covering chronoid, and  $mtbreg$ , relating mereologically minimal time boundary regions with the regions they are a boundary of. Furthermore,  $Chron$  is now equipped with a definition and most other definitions are adapted, except for  $ft, lt, meets, tb, tov, tppart$ .

Note that the relations  $starts, ends, and during$  are originally defined for chronoids (cf. Allen’s relations (1983)). One option of adapting these to time regions would be to consider those relations componentwise, i.e., for all chronoid components of two time regions. Since time regions can possess many connected components this leads to a very large number of conditions expressing how these chronoid components are associated in terms of  $starts, ends, and during$ . More precisely, consider two time regions with  $m$  and  $n$  chronoid components, respectively. Each of the  $m$  components of one time region may be related by any of those relations with any of the  $n$  components of the other time region. All such combinations can be explicitly defined, which results in a set  $DF^{sed}(m, n)$  of definitions. For describing the possible combinations of associations which may hold between two time regions in general, we then get an infinite set of definitions  $Comb^{sed} = \bigcup_{m, n \in \mathbb{N}} DF(m, n)$ , i.e., for arbitrary combinations of numbers of components. For our purposes it is inappropriate to introduce a large number of specific predicates for those definitions. Another option is to consider generalizations of  $starts, ends, and during$  that can be formulated independently of the specific number of chronoid components of the arguments. Again, there is a variety of possibilities. The one adopted below is motivated by maintaining the following interplay between the three: for each time region  $R$ , any pair of a  $starts$  fragment  $S$  and an  $ends$  fragment  $E$  of  $R$  (that do not meet) determines a  $during$  fragment  $D$ , such that the mereological sum of  $S, D, and E$  yields  $R$  – and vice versa. For chronoids, i.e., connected time regions, this corresponds to Allen’s relations.

Notably, the relations  $ftb, ltb$  and  $mchron$  are functional in the respective argument, either by stipulation as axioms or as a consequence of the axioms below. Hence we may introduce functional expressions.

### Relations

$$D1. Chron(x) =_{df} Conn(x) \quad (x \text{ is a chronoid})$$

- D2.  $Conn(x) =_{df} TReg(x) \wedge$  (x is a connected time region)  
 $\forall yz( TReg(y) \wedge TReg(z) \wedge \neg tov(y, z) \wedge \forall w(tov(w, y) \vee tov(w, z) \leftrightarrow tov(w, x)) \rightarrow$   
 $\exists uv(mtbreg(u, y) \wedge mtbreg(v, z) \wedge tcoinc(u, v)) )$
- D3.  $Tb(x) =_{df} \exists y mtbreg(x, y)$  (x is a time boundary)
- D4.  $TbReg(x) =_{df} \exists y tbreg(x, y)$  (x is a time boundary region)
- D5.  $TE(x) =_{df} TReg(x) \vee TbReg(x)$  (x is a time entity)
- D6.  $ccmp(x, y) =_{df} Chron(x) \wedge TReg(y) \wedge$  (x is a maximal connected component of y)  
 $tpart(x, y) \wedge \forall z(Conn(z) \wedge tpart(x, z) \wedge tpart(z, y) \rightarrow tpart(z, x))$
- D7.  $comp(x, y) =_{df} TReg(x) \wedge TReg(y) \wedge \exists z(Chron(z) \wedge tpart(x, z) \wedge tpart(y, z))$   
(x and y are compatible time regions)
- D8.  $during(x, y) =_{df} TReg(x) \wedge TReg(y) \wedge tppart(x, y) \wedge$  (generalized “during” relation)  
 $\exists uv(starts(u, y) \wedge ends(v, y) \wedge \neg tov(u, x) \wedge \neg tov(x, v) \wedge \neg tov(u, v) \wedge$   
 $\exists w(\forall s(tov(s, u) \vee tov(s, x) \leftrightarrow tov(s, w)) \wedge \forall t(tov(t, w) \vee tov(t, v) \leftrightarrow tov(t, y))))$ <sup>27</sup>
- D9.  $ends(x, y) =_{df} TReg(x) \wedge TReg(y) \wedge tppart(x, y) \wedge tppart(mchr(x), mchr(y)) \wedge$   
 $\exists z(ltb(z, x) \wedge ltb(z, y)) \wedge \forall u(tpart(u, mchr(x)) \wedge tpart(u, y) \rightarrow tpart(u, x))$   
(generalized “ends” relation)
- D10.  $mchron(x, y) =_{df} Chron(x) \wedge TReg(y) \wedge$  (x is the minimal chronoid containing y)  
 $tpart(y, x) \wedge \forall z(Chron(z) \wedge tpart(y, z) \rightarrow tpart(x, z))$
- D11.  $meets(x, y) =_{df} TReg(x) \wedge TReg(y) \wedge \exists uv(ftb(u, x) \wedge ltb(v, y) \wedge tcoinc(u, v))$   
(generalized “meets” relation)
- D12.  $mtbreg(x, y) =_{df} tbreg(x, y) \wedge \neg \exists z(tppart(z, x))$  (x is a minimal time boundary region of y)
- D13.  $starts(x, y) =_{df} TReg(x) \wedge TReg(y) \wedge tppart(x, y) \wedge tppart(mchr(x), mchr(y)) \wedge$   
 $\exists z(ftb(z, x) \wedge ftb(z, y)) \wedge \forall u(tpart(u, mchr(x)) \wedge tpart(u, y) \rightarrow tpart(u, x))$   
(generalized “starts” relation)
- D14.  $tb(x, y) =_{df} ftb(x, y) \vee ltb(x, y)$  (x is a first or last time boundary of y)
- D15.  $tov(x, y) =_{df} \exists z(tpart(z, x) \wedge tpart(z, y))$  (temporal overlap)
- D16.  $tppart(x, y) =_{df} tpart(x, y) \wedge x \neq y$  (proper temporal part-of)

<sup>27</sup>The definition of  $x$  during  $y$  requires a complementary  $starts$ -fragment  $u$  of  $y$  and an  $ends$ -fragment  $v$  of  $y$  for each  $x$  during  $y$ , such that the mereological sum of  $u$ ,  $x$ , and  $v$  yields exactly  $y$ . With a defined notion of *temporal sum* according to  $tsum(x, y, z) =_{df} \forall u(tov(u, x) \vee tov(u, y) \leftrightarrow tov(u, z))$  for  $z$  being the sum of  $x$  and  $y$ , the last line of D8 could be simplified to  $\exists w(tsum(u, x, w) \wedge tsum(w, v, y))$ . However, we do not introduce temporal sum, intersection and complement explicitly in  $\mathcal{BT}^R$  at this stage.

*Functions*

- D17.  $ft(x) = y \leftrightarrow_{df} ftb(y, x)$  (the first time boundary of  $x$  is  $y$ )
- D18.  $lt(x) = y \leftrightarrow_{df} ltb(y, x)$  (the last time boundary of  $x$  is  $y$ )
- D19.  $mchr(x) = y \leftrightarrow_{df} mchron(y, x)$  (the minimal chronoid containing  $x$  is  $y$ )

9.2. *Axioms**Taxonomic Axioms*

- $\overset{T100}{A1.} TE(x)$  (the domain of discourse covers only time entities)
- $\overset{T150}{A2.} \neg \exists x (TReg(x) \wedge TbReg(x))$  (time region and time boundary region are disjoint categories)
- $\overset{T102}{A3.} TReg(x) \wedge TReg(y) \rightarrow comp(x, y)$  (every two time regions are compatible)
- $\overset{T400-1}{A4.} tb(x, y) \rightarrow Tb(x) \wedge TReg(y)$  ( $tb$  relates time boundaries with time regions)
- $\overset{T140}{A5.} tb(x, y) \rightarrow mtbreg(x, y)$  (time boundaries of a time region are minimal boundary regions of it)
- $\overset{T406-7}{A6.} tbreg(x, y) \rightarrow TbReg(x) \wedge TReg(y)$  ( $tbreg$  relates time boundary regions with time regions)
- $\overset{T402-3}{A7.} tcoinc(x, y) \rightarrow Tb(x) \wedge Tb(y)$  (coincidence is a relation on time boundaries)
- $\overset{T404-5}{A8.} tpart(x, y) \rightarrow (TReg(x) \wedge TReg(y)) \vee (TbReg(x) \wedge TbReg(y))$   
( $tpart$  is a relation on either time regions or time boundary regions)

*Structure of single relations*

- $\overset{S000}{A9.} TE(x) \rightarrow tpart(x, x)$  (reflexivity)
- $\overset{S001}{A10.} tpart(x, y) \wedge tpart(y, x) \rightarrow x = y$  (antisymmetry)
- $\overset{S002}{A11.} tpart(x, y) \wedge tpart(y, z) \rightarrow tpart(x, z)$  (transitivity)
- $\overset{S105}{A12.} TReg(x) \rightarrow \exists y (Chron(y) \wedge tpart(y, x))$  (every time region has a chronoid as its part)
- $\overset{S030}{A13.} TReg(x) \rightarrow \exists y (Chron(y) \wedge starts(mchr(x), y))$  (every time region has a future extension)
- $\overset{S040}{A14.} TReg(x) \rightarrow \exists y (Chron(y) \wedge ends(mchr(x), y))$  (every time region has a past extension)
- $\overset{S051}{A15.} TReg(x) \rightarrow \exists y (during(y, x))$  (during every time region there is another one)
- $\overset{S060}{A16.} TReg(x) \rightarrow \exists y (ftb(y, x))$  (every time region has a first time boundary)
- $\overset{S070}{A17.} TReg(x) \rightarrow \exists y (ltb(y, x))$  (every time region has a last time boundary)
- $\overset{S100}{A18.} TReg(x) \wedge ftb(y, x) \wedge ftb(z, x) \rightarrow y = z$  (the first boundary of time regions is unique)

A19.<sup>S101</sup>  $TReg(x) \wedge ltb(y, x) \wedge ltb(z, x) \rightarrow y = z$  (the last boundary of time regions is unique)

A20.<sup>S240</sup>  $TReg(x) \wedge TReg(y) \rightarrow \exists z(\forall w(tov(w, x) \vee tov(w, y) \leftrightarrow tov(w, z)))$   
(for every pair of time regions  $x$  and  $y$ , their mereological union exists)

A21.<sup>S080</sup>  $TbReg(x) \rightarrow \exists y(tbreg(x, y))$  (time boundary regions are boundary regions of time regions)

A22.<sup>S500</sup>  $Tb(x) \rightarrow tcoinc(x, x)$  (reflexivity)

A23.<sup>S501</sup>  $tcoinc(x, y) \rightarrow tcoinc(y, x)$  (symmetry)

A24.<sup>S502</sup>  $tcoinc(x, y) \wedge tcoinc(y, z) \rightarrow tcoinc(x, z)$  (transitivity)

A25.<sup>S510</sup>  $Tb(x) \rightarrow \exists y(x \neq y \wedge tcoinc(x, y))$  (every time boundary coincides with another one)

A26.<sup>S511</sup>  $tcoinc(x, y) \wedge tcoinc(x, z) \rightarrow x = y \vee x = z \vee y = z$  (at most two distinct time boundaries coincide)

### Interaction axioms

A27.<sup>I101</sup>  $tov(x, y) \rightarrow \exists z(tpart(z, x) \wedge tpart(z, y) \wedge \forall u(tpart(u, x) \wedge tpart(u, y) \leftrightarrow tpart(u, z)))$   
(two overlapping time regions have an intersection)

A28.<sup>I142</sup>  $TReg(x) \wedge TReg(y) \wedge x \neq y \rightarrow \exists z(\forall u(tpart(u, z) \leftrightarrow tpart(u, x) \wedge \neg tov(u, y)))$   
(for distinct time regions, there is the relative complement)

A29.<sup>I100</sup>  $TReg(x) \wedge TReg(y) \wedge \neg tpart(x, y) \rightarrow \exists z(tpart(z, x) \wedge \neg tov(z, y))$   
(where one time region is not a part of another one, there exists a non-overlapping part)

A30.<sup>J044</sup>  $TReg(x) \rightarrow \forall y(mchron(y, x) \leftrightarrow Chron(y) \wedge ft(x) = ft(y) \wedge lt(x) = lt(y))$   
(the least containing chronoid of a time region is the one between its boundaries)

A31.<sup>J003</sup>  $Chron(x) \wedge Chron(y) \wedge tcoinc(ft(x), ft(y)) \wedge tcoinc(lt(x), lt(y)) \rightarrow x = y$   
(there are no distinct chronoids with coincident boundaries)

A32.<sup>J001</sup>  $tcoinc(x, y) \rightarrow \neg \exists z((ftb(x, z) \wedge ltb(y, z)) \vee (ltb(x, z) \wedge ftb(y, z)))$   
(coincident boundaries are boundaries of distinct time regions)

A33.<sup>J002</sup>  $Tb(x) \wedge Tb(y) \wedge \neg tcoinc(x, y) \rightarrow$   
 $\exists z(Chron(z) \wedge ((tcoinc(x, ft(z)) \wedge tcoinc(y, lt(z))) \vee (tcoinc(x, lt(z)) \wedge tcoinc(y, ft(z)))))$   
(between any two non-coincident time boundaries there is a corresponding chronoid)

A34.<sup>J100</sup>  $Chron(x) \wedge Chron(y) \wedge ftb(u, x) \wedge ftb(v, y) \wedge tcoinc(u, v) \rightarrow (tpart(x, y) \vee tpart(y, x))$   
(for chronoids, coincident first boundaries entail parthood of the chronoids)

A35.<sup>J101</sup>  $Chron(x) \wedge Chron(y) \wedge ltb(u, x) \wedge ltb(v, y) \wedge tcoinc(u, v) \rightarrow (tpart(x, y) \vee tpart(y, x))$   
(for chronoids, coincident last boundaries entail parthood of the chronoids)

A36.<sup>K003</sup>  $Chron(x) \wedge Chron(y) \wedge \exists u(Chron(u) \wedge ft(u) = ft(y) \wedge tcoinc(lt(u), ft(x))) \wedge$   
 $\exists v(Chron(v) \wedge tcoinc(ft(v), lt(x)) \wedge lt(v) = lt(y)) \rightarrow during(x, y)$   
(chronoid  $x$  is during  $y$  if  $x$  is embedded between two chronoids with appropriate boundaries)

A37.<sup>L002</sup>  $TReg(x) \wedge TReg(y) \wedge tpart(x, y) \wedge ft(x) \neq ft(y) \rightarrow \exists z(starts(z, y) \wedge tcoinc(lt(z), ft(x)))$   
 (for every part with distinct first boundaries there is a corresponding starts-fragment)

A38.<sup>L003</sup>  $TReg(x) \wedge TReg(y) \wedge tpart(x, y) \wedge lt(x) \neq lt(y) \rightarrow \exists z(ends(z, y) \wedge tcoinc(ft(z), lt(x)))$   
 (for every part with distinct end boundaries there is a corresponding ends-fragment)

A39.<sup>L000</sup>  $Chron(x) \wedge Chron(y) \wedge meets(x, y) \rightarrow$  (the sum of meeting chronoids is a chronoid)  
 $\exists z(Chron(z) \wedge ft(x) = ft(z) \wedge lt(y) = lt(z) \wedge \neg \exists u(tpart(u, z) \wedge \neg tov(u, x) \wedge \neg tov(u, y)))$

A40.<sup>L001</sup>  $Chron(x) \wedge Chron(y) \wedge tov(x, y) \wedge \exists w(starts(w, x) \wedge \neg tov(w, y)) \rightarrow$   
 $\exists z(Chron(z) \wedge ft(x) = ft(z) \wedge lt(y) = lt(z) \wedge \neg \exists u(tpart(u, z) \wedge \neg tov(u, x) \wedge \neg tov(u, y)))$   
 (the sum of overlapping chronoids is a chronoid)

### 9.3. Entailments

In this section we have gathered preliminary results on consequences of the axiomatization  $\mathcal{BT}^{\mathcal{R}}$ . Table 6 lists them together with the axioms from which they can be proved. The row with consequence A29 illustrates that  $\mathcal{BT}^{\mathcal{R}}$  is not constituted by a set of independent axioms, as is the case for  $\mathcal{BT}^{\mathcal{C}}$ .

C1.<sup>S130</sup>  $Chron(x) \leftrightarrow ccmp(x, x)$   
 (chronoids are exactly those time regions that are their own connected component)

C2.<sup>S110</sup>  $Chron(x) \leftrightarrow mchr(x) = x$   
 (chronoids are exactly those time regions that are their own least containing chronoids)

C3.<sup>S121</sup>  $TReg(x) \wedge mchron(y, x) \wedge mchron(z, x) \rightarrow y = z$   
 (minimal chronoids of a time region are uniquely determined)

C4.<sup>S120</sup>  $TReg(x) \rightarrow \exists y(mchron(y, x))$  (each time region is framed by a least chronoid)

C5.<sup>S220</sup>  $TReg(x) \rightarrow \exists y(Chron(y) \wedge tpart(y, x))$  (every time region has a chronoid as proper part)

Sub theory	Consequence
D8, D16, A15, A28	A29
D1, D2, D5, D6, A9, A10	C1
D10, D19	C2
D10, A10	C3
A16, A17, A30, A31, A32, A33	C4
D8, D16, A10, A11, A12, A15	C5

Table 6  
Entailment relations in system  $\mathcal{BT}^{\mathcal{R}}$ .

## 10. Metalogical Analyses of $\mathcal{BT}^{\mathcal{R}}$

This section provides first observations and results concerning the metalogical properties of  $\mathcal{BT}^{\mathcal{R}}$ . We start by considering the numbers of maximal components that can occur within time regions. Consistency can be proved in a way which is very similar to the case of  $\mathcal{BT}^{\mathcal{C}}$ . Moreover, we discuss the incompleteness of the current theory and an option for a complete extension. The remaining considerations are concerned

with a systematic approach to the classification of time regions on the basis of  $\mathcal{BT}^{\mathcal{R}}$  as a first-order theory, and we briefly look at the relationship with  $\mathcal{BT}^{\mathcal{C}}$ .

As a note on future investigations, the mereology of time regions is of particular interest regarding the proposed time theory. Axioms A20, A27 and A28 postulate that the time regions are closed with respect to the boolean operations of mereological union as well as – under certain conditions – intersection and relative complement. A more detailed investigation should thus reveal that the time regions form a relatively complemented distributive lattice.

### 10.1. Cardinality Considerations on the Components of Time Regions

Here we focus on the aspect of how many maximal connected components are guaranteed to be comprised in set of all time regions in models of  $\mathcal{BT}^{\mathcal{R}}$ . For this purpose, we refer to a time region with *exactly*  $n$  maximal connected components as an  $n$ -time region, and use the following abbreviating notation, defined for each natural number  $n \in \mathbb{N}$ .

$$treg_n(x) := TReg(x) \wedge \exists x_1 \dots x_n . \bigwedge_{1 \leq i \leq n} ccmp(x_i, x) \wedge \bigwedge_{1 \leq i < j \leq n} x_i \neq x_j \wedge \forall y (ccmp(y, x) \rightarrow \bigvee_{1 \leq i \leq n} y = x_i)$$

This allows for a clear specification of the first observation, namely that time regions within  $\mathcal{BT}^{\mathcal{R}}$  are not limited in terms of the number of their components.

**Proposition 5.**  $\mathcal{BT}^{\mathcal{R}}$  ensures that there is an  $n$ -time region for every  $n \in \mathbb{N}$ , i.e.,  $\mathcal{BT}^{\mathcal{R}} \models \exists x . treg_n(x)$ .

*Proof.* The proof is by induction on  $n$ . We first show that  $\mathcal{BT}^{\mathcal{R}} \models \exists x . treg_1(x)$ . This can be seen as follows: Definition D5 and axioms A1, A2 imply  $\exists x . TReg(x) \vee TbReg(x)$ . Furthermore, by definition D4 and axiom A6 we have  $\exists x . TReg(x)$ . Given consequence C4 and definition D10 we deduce  $\exists x . Chron(x)$ . Now, using consequence C1 we have  $\exists x . treg_1(x)$  concluding the base case.

Assume now  $\mathcal{BT}^{\mathcal{R}} \models \exists x . treg_n(x)$  for an arbitrary  $n \in \mathbb{N}$ . Let  $r$  an  $n$ -time region and select a single chronoid component  $c$  of  $r$ , i.e.,  $treg_n(r) \wedge ccmp(c, r)$ . With axiom A15 we obtain a new time region  $s$  such that *during*( $s, c$ ). Using definition D8 we deduce the existence of two additional time regions  $s'$  and  $s''$ , complementary to  $c$  within  $r$ , more precisely *starts*( $s', c$ ) and *ends*( $s'', c$ ), which do not overlap nor meet. Applying A12 we derive the existence of two chronoids  $t'$  and  $t''$  being temporal part of  $s'$  or  $s''$ , respectively. By transitivity of temporal part, i.e., axiom A11 we deduce that  $t'$  and  $t''$  do not overlap/meet as well as they cannot overlap nor meet with any of the remaining  $n-1$  connected components of  $r$ . Forming the mereological sum, which can be done via axiom 20, of those remaining components with the containing chronoids of  $s'$  and  $s''$  immediately yields an  $n+1$ -time region, which shows  $\mathcal{BT}^{\mathcal{R}} \models \exists x . treg_{n+1}(x)$  concluding the proof.  $\square$

D20.  $before(x, y) =_{df} \exists uvz (Chron(z) \wedge Tb(u) \wedge Tb(v) \wedge ftb(u, z) \wedge ltb(v, z) \wedge tcoinc(u, x) \wedge tcoinc(v, y))$   
(time boundary  $x$  is strictly before time boundary  $y$ )

$\overset{T120}{C6.} Chron(x) \rightarrow TReg(x)$  (chronoids are time regions)

$\overset{I200}{C7.} Chron(x) \wedge Chron(y) \wedge Chron(z) \wedge tpart(x, y) \wedge tov(x, z) \rightarrow tov(y, z)$   
(a chronoid that overlaps a part of another chronoid overlaps the latter itself)

$\overset{K200}{C8.} ftb(x, y) \rightarrow Tb(x)$  (first time boundaries are time boundaries)

$\overset{K201}{C9.} ltb(x, y) \rightarrow Tb(x)$  (last time boundaries are time boundaries)



- C10.<sup>J200</sup>  $Chron(x) \wedge Chron(y) \wedge tpart(x, y) \rightarrow before(ft(y), ft(x)) \vee tcoinc(ft(y), ft(x))$   
 (the first boundary of a chronoid is before or coincides with those of its parts)
- C11.<sup>J201</sup>  $Chron(x) \wedge Chron(y) \wedge tpart(x, y) \rightarrow before(lt(x), lt(y)) \vee tcoinc(lt(x), lt(y))$   
 (the last boundary of a chronoid is after or coincides with those of its parts)
- C12.<sup>J210</sup>  $Chron(x) \wedge Chron(y) \wedge Chron(z) \wedge tpart(x, y) \wedge meets(x, z) \rightarrow meets(y, z) \vee tov(y, z)$   
 (a chronoid, a part of which meets another chronoid, meets or overlaps the latter)
- C13.<sup>KQ10</sup>  $Chron(x) \wedge Chron(y) \wedge before(ft(x), lt(y)) \wedge before(ft(y), lt(x)) \rightarrow tov(x, y)$   
 (chronoids with mutually interlaced “first boundary-last boundary” pairs overlap)

## Table entries

- for C6:  
D1, D2
- for C7:  
D15, A11
- for C8:  
D17, D14, A4
- for C9:  
D18, D14, A4
- for C10:  
C8, A22, D17, A37, D20
- for C11:  
C9, A22, D18, A38, D20
- for C12:  
D11, D14, D17, D18, C4<sup>BT<sup>c</sup></sup>, C11, ...

This observation can be extended immediately. Proposition C6 below states that there is not only one  $n$ -time region, but there are arbitrarily many. The proof uses C7 and C12, which we combine and prove in the subsequent lemma in order to substantiate them in further entailments of  $\mathcal{BT}^{\mathcal{R}}$  from Table 6.

**Lemma 1.** *In the situation that a part  $x$  of a chronoid  $y$  meets or overlaps another chronoid  $z$ , then the whole  $y$  itself meets or overlaps  $z$ . C7 and C12 in Table 6 capture this connection formally:*

- C7:  $Chron(x) \wedge Chron(y) \wedge Chron(z) \wedge tpart(x, y) \wedge tov(x, z) \rightarrow tov(y, z)$   
 C12:  $Chron(x) \wedge Chron(y) \wedge Chron(z) \wedge tpart(x, y) \wedge meets(x, z) \rightarrow meets(y, z) \vee tov(y, z)$

*Proof.* Starting with C7, let  $c$ ,  $d$ , and  $e$  be chronoids such that  $c$  is a part of  $d$  and overlaps  $e$ . By D15, overlap between  $c$  and  $e$  yields a shared part, which is also shared between  $c$  and  $e$ , because  $tpart$  is transitive (A11). Hence,  $e$  overlaps  $c$ , as well, concluding the proof of C7.

For C12, let a chronoid  $c$  be part of a chronoid  $d$  and  $meets(c, e)$  for a chronoid  $e$ . We must show that  $d$  meets  $e$  or that  $d$  and  $e$  overlap.

Firstly, in the sequel we rely on the fact that  $c$ ,  $d$ , and  $e$  have first and last time boundaries based on axioms A16–A17 (aux.<sup>28</sup> C6), e.g., when using the function symbols  $ft$  and  $lt$ . Moreover, for the latter symbols, we mention only once here that D17 and D18 are required in several proof steps to switch between, say,  $ft$  and  $ftb$ .

Due to  $tpart(c, d)$  and C11, (1)  $lt(c)$  is before  $lt(d)$  or (2) the two boundaries coincide. In the latter case, employing  $Tb(x) \wedge Tb(y) \wedge Chron(u) \wedge Chron(v) \wedge tcoinc(x, y) \wedge ltb(x, u) \wedge ltb(y, v) \rightarrow x = y$ , the

<sup>28</sup>“aux.” stands for “auxiliary”, referring to definitions, formulas, and phrases that are needed in a proof step, yet are less decisive for understanding the proof, but are included here to match the list of required axioms and definitions in Table 6.

reflection of C4 from  $\mathcal{BT}^C$  via the interpretation in section 10.5, we deduce (aux. D14, A4) that  $c$  and  $d$  have the same last time boundary. Given the premise  $meets(c, e)$ , D11 yields that  $lt(c)$  and  $ft(e)$  must coincide, thus with  $lt(c) = lt(d)$  also  $tcoinc(lt(d), ft(e))$ . But then  $d$  meets  $e$ , consequentially of D11 (aux. C6), concluding case (2) successfully.

In case (1) we have  $before(lt(c), lt(d))$  and, as just seen, the premise  $meets(c, e)$  entails  $tcoinc(lt(c), ft(e))$ . The order between  $lt(c)$  and  $lt(d)$ , the latter coincidence and the definition of  $before$  (D20, aux. A24) imply  $before(ft(e), lt(d))$ . A second relation between the boundaries of  $e$  and  $d$  derives from the initial premise  $tpart(c, d)$  and from  $tcoinc(lt(c), ft(e))$ .

Due to C10 (aux.  $c, d$  being chronoids), the first boundary of  $d$  must coincide or be before the first time boundary of  $c$ , and thus in any case before the last boundary of  $c$ . Together with coincidence between  $lt(c)$  and  $ft(e)$  (aux. D20) we find  $before(ft(d), lt(e))$ . That means we have interlaced boundaries between  $d$  and  $e$ :  $before(ft(e), lt(d))$  and  $before(ft(d), lt(e))$  (aux. together with suitable type constraints), satisfying the precondition in C13. Consequently,  $tov(d, e)$  is verified.  $\square$

This observation can be extended immediately. For each  $m, n \in \mathbb{N}$ , let  $treg_n^{\geq m}$  abbreviate the sentence that at least  $m$   $n$ -time regions exist.

$$treg_n^{\geq m} := \exists x_1 \dots x_m . \bigwedge_{1 \leq i < j \leq m} x_i \neq x_j \wedge \bigwedge_{1 \leq i \leq m} treg_n(x_i)$$

**Proposition 6.** *For any non-zero natural numbers  $m, n$  it holds that  $\mathcal{BT}^R \models treg_n^{\geq m}$ .*

*Proof.* The proof idea is to “shorten” one chronoid component of a given  $n$ -time region due to C5, which yields a distinct  $n$ -time region via mereological union, A20. This can be considered multiple times at once.

For any  $n \in \mathbb{N}$ , proposition 5 guarantees the existence of an  $n$ -time region, i.e.,  $\mathcal{BT}^R \models treg_n^{\geq 1}$ . Consider a fixed  $n$ -time region  $t$  and select a single chronoid component  $c$  of it. For any  $m \in \mathbb{N}$ , applying consequence C5  $m$  times yields a  $tppart$ -chain of chronoids. More precisely, we obtain  $tppart(c_1, c), tppart(c_2, c_1), \dots, tppart(c_m, c_{m-1})$  with  $Chron(c_i)$  for all  $1 \leq i \leq m$ . By definition D16 of  $tppart$  as well as the partial order axioms of  $tpart$  (A9, A10, and A11),  $c_i \neq c_j$  results for any  $1 \leq i < j \leq m$ . Moreover, by transitivity of temporal part (A11) we deduce that the constructed  $c_i$ s cannot overlap nor meet with any of the remaining  $n - 1$  connected components of  $t$ . For each  $1 \leq i \leq m$ , let  $r_i$  be the mereological sum of  $c_i$  and the remaining connected components of  $t$ , which exists by A20. These temporal entities are distinct and obviously  $n$ -time regions by construction. Consequently,  $\mathcal{BT}^R \models treg_n^{\geq m}$  is shown, concluding the proof.  $\square$

*Proof.* (sketch) First consider the case of 1-time regions, i.e., chronoids. A single chronoid immediately gives rise to an arbitrary number of chronoids by considering chains of the *during* relation, i.e., considering chronoids  $s_1, \dots, s_m$  such that  $during(s_{i+1}, s_i)$  for all  $1 \leq i < m$ . A central justification for the existence of such chains is axiom A15, which postulates for every chronoid  $s_i$  that there must be a time region, called  $t_{i+1}$ , during  $s_i$ . By D8 we have  $tppart(t_{i+1}, s_i)$ , hence  $t_{i+1}$  is distinct from that given chronoid  $s_i$  and, involving e.g. antisymmetry of parthood A10,  $t_{i+1} \neq s_k$  for  $1 \leq k \leq i$ . By axiom A33, there is a chronoid  $s_{i+1}$  with the same boundaries as  $t_{i+1}$ , thus distinct from all  $s_k$  ( $1 \leq k \leq i$ ). Since chronoids are connected time regions, this yields  $during(s_{i+1}, s_i)$ , as well, for all  $1 \leq i < m$ , and shows that there are at least  $m$  1-time regions.

For an  $n$ -time region  $r_1$  with  $n \geq 2$ , fix an arbitrary connected component  $s_1$  of  $r_1$ , which must be a chronoid by D1. Accordingly, the argumentation just given for chronoids applies to  $s_1$ , yielding series  $s_1, \dots, s_m$  of distinct chronoids for any  $m \in \mathbb{N}$ . Moreover, all  $s_i$  are parts of  $s_1$  and do not overlap with any of the remaining  $n - 1$  connected components of  $r_1$ , or equivalently, with the mereological sum  $u$  of those  $n - 1$  connected components. For each  $1 \leq i \leq m$ , let  $r_i$  be the mereological sum of  $s_i$  and  $u$ , which exists by A20 and is  $n$ -time region due to the previous consideration. As a consequence of the distinctness of all  $s_i$ , this proves the existence of at least  $m$  distinct  $n$ -time regions  $r_1, \dots, r_m$ .  $\square$

Results of this kind turn out to be useful in considering the completeness of  $\mathcal{BT}^{\mathcal{R}}$  as well as ways of classifying time regions. But prior to both, the consistency of the theory should be established.

### 10.2. Consistency of $\mathcal{BT}^{\mathcal{R}}$

A proof of the (relative) consistency of  $\mathcal{BT}^{\mathcal{R}}$  can be achieved by a reduction of this theory to the monadic second order theory of linear orderings that is very similar to the one used in the proof of  $\mathcal{BT}^{\mathcal{C}}$ 's consistency in section 7. The major addition is to capture the intuitive understanding of time regions as mereological sums of chronoids.

**Proposition 7.** *The theory  $\mathcal{BT}^{\mathcal{R}}$  is consistent.*

*Proof.* Let  $\lambda$  be the order type of the real numbers  $\mathbb{R}$ . Then take the linear ordered sum over  $\mathbb{R}$  of linear orderings of type  $\mathbf{2}$  to define a new linear ordering  $\mathcal{M} = (M, \leq)$  of type  $\lambda(\mathbf{2})$ . Within the monadic second order theory of  $\mathcal{M}$ , we must provide definitions for the basic signature elements of  $\mathcal{BT}^{\mathcal{R}}$ ,  $TReg$ ,  $ftb$ ,  $ltb$ ,  $tbreg$ ,  $tcoinc$ , and  $tpart$ .

Defining time regions requires some preparation, where we aim at identifying a time region  $R$  with a union of a finite number of pairwise disjoint chronoids, the latter being captured as in the consistency proof of  $\mathcal{BT}^{\mathcal{C}}$ . Accordingly and as an auxiliary means, we define  $Chron(C)$  such that  $C$  is a chronoid if and only if  $C$  is an interval  $[a, b]$  over  $M$  whose first element  $a$  has an immediate predecessor and whose last element  $b$  has an immediate successor. Consequently, chronoids are convex subsets of  $M$ . Furthermore, the first and the last boundary of a chronoid are determined by the corresponding elements of the associated interval, i.e., we set  $ftb(a, C)$  and  $ltb(b, C)$  for  $C = [a, b]$ . Notice that disjoint chronoids / intervals can be ordered by their first time boundaries / least elements. More precisely, a set  $\mathcal{C}$  of pairwise disjoint chronoids has an associated linear order  $(\mathcal{C}, \triangleleft)$  that derives from  $\mathcal{M}$  by  $C \triangleleft D$  iff  $ftb(x, C)$  and  $ftb(y, D)$  and  $x < y$ .

Now time regions are defined as any subset  $R \subseteq M$  of  $M$  that satisfies the conditions

1. Regarding  $\leq$ ,  $R$  has a least element  $s$  and a greatest element  $t$  such that  $s$  has an immediate predecessor and  $t$  has an immediate successor.
2. Every maximal convex subset of  $R$  satisfies the conditions of a chronoid.
3. The linear ordering between the maximal convex subsets of  $R$ , determined by the linear ordering of their first elements, does not contain any subset of order type  $\omega$  or  $\omega^*$ .

All of these conditions can be expressed by a monadic second order formula for defining  $TReg(R)$ , which is satisfied by those subsets of  $M$  representing time regions. The finiteness of the number of components follows from the non-existence of suborderings of type  $\omega$  or  $\omega^*$ .

The remaining predicates are more straightforward. Also in the general case of time regions  $R$ ,  $ftb(x, R)$  applies if  $x$  is the least element of  $R$ , and  $ltb(x, R)$  if  $x$  is the greatest element of  $R$ . The set  $B(R)$  of all time boundaries of  $R$  is defined as the set of all least and greatest elements of the chronoids included in  $R$ . The relation  $tbreg(X, R)$  is satisfied if  $X$  is a non-empty subset of  $B(R)$ . Two distinct boundaries *coincide* if one is an immediate successor of the other. Eventually, *temporal part-of* corresponds to the subinterval relation.

The definitions of the  $\mathcal{BT}^{\mathcal{R}}$  primitives allow for extracting a new structure  $\mathcal{A}$  with  $\mathcal{A} \models \mathcal{BT}^{\mathcal{R}}$ . We omit the technical proof steps that show that all axioms of  $\mathcal{BT}^{\mathcal{R}}$  are satisfied in  $\mathcal{A}$ .  $\square$

### 10.3. $\mathcal{BT}^{\mathcal{R}}$ and the Problem of Completeness

Following the case of  $\mathcal{BT}^{\mathcal{C}}$  anew, further metalogical considerations on  $\mathcal{BT}^{\mathcal{R}}$  concern its completeness. Given the existence of an axiomatization, completeness of a theory further yields decidability (Enderton, 1993, p. 147). The theory  $\mathcal{BT}^{\mathcal{C}}$  was proved to be complete in section 7.2. The situation for  $\mathcal{BT}^{\mathcal{R}}$  turns out to be different.

**Proposition 8.** *The theory  $\mathcal{BT}^{\mathcal{R}}$  is incomplete.*

In order to see this we construct a sentence  $\phi$  such that both of the sentences  $\phi$  and  $\neg\phi$  are consistent with  $\mathcal{BT}^{\mathcal{R}}$ . Section 10.1 proves that every  $\mathcal{BT}^{\mathcal{R}}$  model contains time regions with  $n$  different components for each natural number  $n$ . But nothing can be proved about the structure of time regions with infinitely many components. By the completeness (compactness) theorem of first-order logic, cf. e.g. (Enderton, 1993, sect. 2.5), one can derive that there are models of  $\mathcal{BT}^{\mathcal{R}}$  in which there exist time regions with infinitely many components. This suggests a direction to search for a sentence that is undetermined.

*Proof.* We aim at a sentence  $\phi$  such that  $\mathcal{BT}^{\mathcal{R}} \cup \{\phi\}$  as well as  $\mathcal{BT}^{\mathcal{R}} \cup \{\neg\phi\}$  are consistent. The basic idea for  $\phi$  rests on the observation that the chronoid components of any time region form a pairwise non-overlapping set of chronoids and thus can be linearly ordered by adopting, e.g., their first time boundaries' ordering (as via  $\triangleleft$  in the consistency proof in the previous section 10.2). Then the sentence  $\phi$  shall state that there is a time region  $r$  where this ordering of its chronoid components is dense and, therefore,  $r$  has infinitely many components.

Approaching  $\phi$  formally, we introduce the predicate  $cbf(x, y)$  and, by definition, let it reflect the mentioned ordering  $\triangleleft$  of non-overlapping chronoids. Note that this definition reuses the definition of *before*, the strict linear ordering among time boundaries (see D13 in section 6.3). Thus linearity of  $cbf$  follows from the definition and additional considerations that non-overlap behaves accordingly.

---

1105: adapt to before  
in TReg?

---

$$D21. \text{ } cbf(x, y) =_{df} Chron(x) \wedge Chron(y) \wedge \neg tov(x, y) \wedge before(ft(x), ft(y))$$

(chronoid  $x$  is before or meets  $y$ )

Now let us specify  $\phi$ , following the ideas above. While  $cbf(x, y)$  itself does not exclude that its arguments meet instead of being properly before one another, this is irrelevant in  $\phi$  because only maximal connected components are considered therein.

$$\phi : \exists x(TReg(x) \wedge \forall uw(ccmp(u, x) \wedge ccmp(w, x) \wedge cbf(u, w) \rightarrow \exists v(ccmp(v, x) \wedge cbf(u, v) \wedge cbf(v, w))))$$

Based on the consistency proof it is immediate that  $\mathcal{BT}^{\mathcal{R}} \cup \{\neg\phi\}$  is consistent, because all time regions in the corresponding structures of the proof are restricted to a finite number of components. On the other hand, condition 3 in section 10.2 may be omitted from the definition of time regions. It is then straightforward to extend it in order to demonstrate also the consistency of  $\mathcal{BT}^{\mathcal{R}} \cup \{\phi\}$ .  $\square$

$\mathcal{BT}^{\mathcal{R}}$  can be extended such that the sentence  $\phi$  is no longer consistent with that extension. One option for that is certainly  $\neg\phi$ . Another is to add a sentence  $\psi$  saying that, for every time region  $r$ , every component of  $r$  that is neither the greatest nor the least element with respect to  $cbf$  has an immediate successor and an immediate predecessor.

Besides the sentence  $\phi$ , we are currently examining further properties of time regions that seem to be independent, even of  $\mathcal{BT}^{\mathcal{R}} \cup \{\neg\phi\}$  or  $\mathcal{BT}^{\mathcal{R}} \cup \{\psi\}$ . Nevertheless, let us conclude our considerations on the completeness of a theory for time regions with an, admittedly speculative, hypothesis.

**Conjecture 1.** *The theory  $\mathcal{BT}^{\mathcal{R}}$  can be completed by a finite (and readily comprehensible) number of axioms, such that the corresponding extension yields a decidable theory of time regions.*

#### 10.4. Classification of Time Regions

Classifying the entities of a domain is a fundamental task for formal ontology, where we are especially interested in systematic approaches to classification. With formalized ontologies available, the objects of a domain can be classified with respect to elementary properties (in the formal-logical sense) that are expressible in the language of the ontology (cf. also Baumann & Herre, 2011, sect. 5).

Let us outline this approach in a little more detail with respect to time regions. The basic idea is to consider a time region  $r$  within any model  $\mathcal{A}$  of  $\mathcal{BT}^{\mathcal{R}}$ ,  $r \in TReg^{\mathcal{A}}$ , and associate with it a relational structure  $\mathcal{S}(r)$  that can be derived from  $\mathcal{A}$ . For instance, one may assign a relational structure to such an  $r$

by  $\mathcal{S}(r) := (Parts(r), TbReg, tpart, ftb, ltb, tcoinc)$ , where  $Parts(r) = \{p \mid tpart^A(p, r)\}$  and further relations are restricted corresponding to members in  $Parts(r)$  and elements in  $\mathcal{A}$  related to them, e.g.  $ftb = \{(x, y) \in ftb^A \mid y \in Parts(r)\}$ . The elementary type of  $r$  is defined by the theory  $Th(\mathcal{S}(r))$ , and any two time regions are said to be elementary equivalent if their theories coincide.

This general approach allows for studying novel connections between metalogical properties and classification. In the context of the present theory, we can provide the following example. A time region is said to be *standard* if it contains only a finite number of connected components. Otherwise, a time region is called *non-standard*. Now we can formulate the following hypothesis for  $\mathcal{BT}^{\mathcal{R}}$ .

**Conjecture 2.** *Two standard time regions are elementary equivalent if they contain the same number of connected components.*

The classification of the *non-standard* time regions is more complicated and is among our future investigations, together with a rigorous proof of the conjecture.

### 10.5. Relationship with $\mathcal{BT}^{\mathcal{C}}$

In relating  $\mathcal{BT}^{\mathcal{R}}$  with other theories of time it is natural to first consider the relation with the ontology that has served as its foundation,  $\mathcal{BT}^{\mathcal{C}}$ . This is the main relationship to be discussed in this paper, while analyses of connections to other time theories remain for the future.

Looking “back” from  $\mathcal{BT}^{\mathcal{R}}$  to  $\mathcal{BT}^{\mathcal{C}}$  it is tempting to expect that the latter has just become a subtheory of the former. However, already the combination of the domain coverage axiom  $\forall x TE(x)$  (itself contained in both theories as A1) with distinct definitions of the predicate  $TE(x)$  for “time entities” in both theories suggests a more complex relationship.

As a next step, one may consider the relativation of each  $\mathcal{BT}^{\mathcal{C}}$  axiom to the unary predicates  $Chron(x)$  and  $Tb(x)$ , i.e., basically, guarding quantification by one of these predicates, cf. (Rautenberg, 2010, p. 258).<sup>29</sup> But even this approach fails, because further basic extensions have lead to stronger deviations. An example already visible in the diagrammatic surveys in Figures 3 and 4 is the “lifting” of temporal part-of from being regarded in connection with chronoids only in  $\mathcal{BT}^{\mathcal{C}}$  to becoming applicable to time boundary regions in  $\mathcal{BT}^{\mathcal{R}}$ , and in particular, to time boundaries, as well. Let  $\varphi$  be the sentence  $\forall x Tb(x) \rightarrow \neg tpart(x, x)$  and observe that this formula has already the form of a relativation. Because of  $\mathcal{BT}^{\mathcal{C}} \models \varphi$ , but  $\mathcal{BT}^{\mathcal{R}}$  being inconsistent with  $\varphi$  (mainly) due to its axiom A9, it is not in general the case that all  $\mathcal{BT}^{\mathcal{C}}$  relativations are consequences of the presented theory of time regions.

Eventually, looking for an interpretation from the theory of chronoids into the theory of time regions is a fairly general means, but it turns out to be successful.

**Proposition 9.** *The theory  $\mathcal{BT}^{\mathcal{C}}$  is interpretable in  $\mathcal{BT}^{\mathcal{R}}$ .*

We merely outline the proof by specifying definitions of the  $\mathcal{BT}^{\mathcal{C}}$  primitives against the background of  $\mathcal{BT}^{\mathcal{R}}$ , while it is straightforward, yet technically cumbersome, that all (relativized)  $\mathcal{BT}^{\mathcal{C}}$  axioms must then be proved within  $\mathcal{BT}^{\mathcal{R}}$ .

*Proof.* (outline) Analogously to providing the interpretation of  $\mathcal{IP}_{\text{dense}}$  in  $\mathcal{BT}^{\mathcal{C}}$  in section 7.3, a set of explicit definitions  $\Delta$  is specified such that the five basic signature elements of  $\mathcal{BT}^{\mathcal{C}}$  are defined by formulas in the language of  $\mathcal{BT}^{\mathcal{R}}$  (cf. Rautenberg, 2010, sect. 6.6). Clearly, on that basis the defined signature elements of  $\mathcal{BT}^{\mathcal{C}}$  are uniquely determined, as well. We use the upper indices  $\mathcal{C}$  and  $\mathcal{R}$  to distinguish between predicate names in  $\mathcal{BT}^{\mathcal{C}}$  and  $\mathcal{BT}^{\mathcal{R}}$ , respectively.

<sup>29</sup>If this approach could be pursued successfully, the domain coverage axiom A1 just mentioned would require a special treatment.

$$\text{CD1. } Chron^C(x) =_{df} Chron^R(x)$$

$$\text{CD2. } ftb^C(x, y) =_{df} Tb^R(x) \wedge Chron^R(y) \wedge ftb^R(x, y)$$

$$\text{CD3. } ltb^C(x, y) =_{df} Tb^R(x) \wedge Chron^R(y) \wedge ltb^R(x, y)$$

$$\text{CD4. } tcoinc^C(x, y) =_{df} tcoinc^R(x, y)$$

$$\text{CD5. } tpart^C(x, y) =_{df} Chron^R(x) \wedge Chron^R(y) \wedge tpart^R(x, y)$$

Quantification regarding  $\mathcal{BT}^C$  is strictly limited compared to  $\mathcal{BT}^R$ , to the extent that the intended domain of  $\mathcal{BT}^C$  covers only chronoids and time boundaries, while  $\mathcal{BT}^R$  comprises in addition time regions and time boundary regions. Accordingly, the axioms of  $\mathcal{BT}^C$  must be relativized to chronoids and time boundaries only, before their validity in  $\mathcal{BT}^R$  is considered. Remembering definition D2 and axiom A1 in  $\mathcal{BT}^C$ , predicate  $TE^C$  can serve as relativation predicate. The respective closure axioms (see Rautenberg, 2010, p. 258–259) in this case require  $\exists x(TE^C(x))$ , which  $\mathcal{BT}^R$  entails based on its axioms, e.g., the subset of D14, A1, A4, A6, A13, A16, and A21.

Now, for any  $\mathcal{BT}^C$  formula  $\varphi$ , let  $\hat{\varphi}$  denote the relativation of  $\varphi$  to  $TE^C$ . The overall proof is completed by showing  $\mathcal{BT}^R \cup \Delta \models \hat{\varphi}$  for each axiom  $\varphi \in \mathcal{BT}^C$ .  $\square$

Despite a theory interpretation being used to establish the link between the two main theories in this paper, obviously there is a strong formal tie between them, not only one by construction. The high proximity of the definitions CD1–CD5 to the case of relativation is one indication. Another may be drawn from the consistency proofs of both theories, where the predicates shared (intuitively) among the theories are defined in (almost) exactly the same way.

## 11. Time Regions in Applications

Temporal regions are ubiquitous in many applications. Let us conclude the overall proposal of an ontology that provides for time regions in addition to chronoids and time boundaries with a discussion of its applications. In particular, we focus on one type of applications related to the notion of temporal abstraction (cf. Shahar, 1994), demonstrated by some examples.

The basic problem of temporal abstraction consists in interpreting time-indexed data by temporal propositions. This problem pertains to an aspect of the inverse problem of the incidence problem in temporal logic. The incidence problem consists in the establishment of a truth relation between temporal propositions and spatio-temporal reality, cf. section 3.1. Temporal abstraction is focused on the task of constructing temporal propositions from partial information about spatio-temporal reality such that these propositions are considered to be true in reality. The constructed temporal propositions exhibit an interpretation and understanding of the data, anchored in reality. A solution of this task must solve several sub-tasks, among them the following three most basic ones.

1. The development of an ontology of parts of the real world that can serve as truth-makers for temporal propositions.
2. The development of a theory of temporal propositions together with a truth relation, which links propositions and truth-makers.
3. The development of methods for constructing true temporal propositions from partial information about the real world.

There is no general solution to these problems, although there are various partial results, notably in practical applications related to medical decision support systems.

Furthermore, one observes that there are several levels of abstraction. In this connection, time-indexed data can be abstracted into a temporal region, such that certain properties are attached to the connected components. An example is the course of disease of malaria, where there are phases of high fever with interruptions in between. Put differently, the property of high fever is distributed over the connected components of a time region. Usually the temporal structure of the first abstraction level in temporal abstraction is a time region, but not a chronoid (a time interval). On levels of higher abstraction several separate connected components from the lower level(s) may be united, resulting in a more coarse-grained temporal region. In many cases, after a number of steps of abstraction, one reaches an abstraction that links one property to a connected time region.

## 12. Conclusions and Future Work

In this paper we present a new approach to phenomenal time, which is adopted by the top-level ontology GFO (Herre, 2010). The approach is elaborated in two consecutive theories,  $\mathcal{BT}^C$  and  $\mathcal{BT}^R$ , both being inspired in their foundations by ideas of Franz Brentano (1976). The basic concepts of  $\mathcal{BT}^C$  are *chronoids* (time intervals) and *time boundaries* (time points).  $\mathcal{BT}^R$  is based on generalizations of these concepts that originate from forming mereological sums, namely *time regions* and *time boundary regions*, respectively. The basic relations are *temporal part-of* either among time regions or among time boundary regions, *temporal coincidence of time boundaries*, and relations that link a time boundary (region) and a time region (including chronoids), declaring the former as a boundary of the latter, such as being the *first* or the *last time boundary* of a region.

Both ontologies are formalized by a set of axioms, specifying logical interrelationships between the categories and the relations. They serve as the basis for the development of a comprehensive ontology of material entities, including continuants and processes. In this connection as well as in general, we understand the metalogical analysis of formalized ontologies to be an important task. Herein, corresponding investigations concern the consistency of both systems, their completeness and decidability, and a few more theory-specific considerations in both cases. Moreover, the relation between  $\mathcal{BT}^R$  and  $\mathcal{BT}^C$  is discussed and the latter is formally related to  $\mathcal{IP}_{\text{dense}}$  (Vila, 2005), which has close links to the well-established interval theory of time of Allen and Hayes (1985; 1989). These metalogical analyses result in, firstly, proving both presented theories to be consistent. Only  $\mathcal{BT}^C$  can be shown to be complete and thus decidable, whereas  $\mathcal{BT}^R$  is provably incomplete, leaving room for hypotheses of potential complete extensions. The theory  $\mathcal{IP}_{\text{dense}}$  is interpretable in  $\mathcal{BT}^C$ , and the latter is interpretable in  $\mathcal{BT}^R$ .

We see a number of potential benefits and applications for the overall approach to time proposed in this work. Regarding ontological adequacy, we believe that the temporal continuum can be introspectively accessed without any metrics, and that it cannot be understood and grasped by sets of points. Accordingly, our approach does not rely on such a reduction. Secondly, it establishes a basis that allows for expressing various solutions to the Dividing Instant Problem (cf. Allen, 1983; Strobach, 1998) consistently and in the classical framework of first-order logic. Several other contributions are discussed in the paper, among them the potential use of time regions in connection with the problem of temporal abstraction. Further we expect a series of new applications. In other contexts, we have already verified the usefulness of our ontology as a tool for modeling cellular genealogies (Burek et al., 2010) and surgical interventions (Neumuth et al., 2011), for instance.

Concerning future work, there is a large number of open problems and tasks that can be classified into logical, ontological, and semantical problems. Logically and ontologically, both theories can be further analyzed and extended in several directions. In particular  $\mathcal{BT}^R$  is proposed as a first version of an axiom system to specify the theory of the domain of time regions. Naturally and in general, modifications of the axioms may be required based on further analysis and use. Of particular importance, likewise regarding ontological aspects, is the (continued) connection and combination of the theories of time with those of other domains, e.g. of objects and processes in the material stratum. An open logical problem is to find minimal sets of axioms, such that each axiom is independent of the remaining theory. Another comprises

the continued study of relations to other theories in the domain of time. For example, we are interested in connections with PSL (Grüninger, 2004), selected theories in (Hayes, 1995), and the FOL variant of OWL-Time (Hobbs & Pan, 2006).

The main semantical problem concerns the temporal incidence problem for propositions, already touched upon in sections 3.1, 5.1, and 11. We expect that an expressive ontology of truthmakers must be established as a semantic basis for the interpretation of temporal propositions. Any such solution will depend on an underlying ontology of time.

## References

- Allen, J. F. (1983). Maintaining knowledge about temporal intervals. *Communications of the ACM*, 26(11), 832–843.
- Allen, J. F. (1984). Towards a general theory of action and time. *Artificial Intelligence*, 23(2), 123–154.
- Allen, J. F., & Hayes, P. J. (1985). A common-sense theory of time. In A. K. Joshi (Ed.), *Proceedings of the 9th International Joint Conference on Artificial Intelligence, IJCAI 1985, Los Angeles, California, USA, Aug 18-23* (pp. 528–531). Los Altos, California, USA: Morgan Kaufmann.
- Allen, J. F., & Hayes, P. J. (1989). Moments and points in an interval-based temporal logic. *Computational Intelligence*, 5(3), 225–238.
- Balbani, P., Goranko, V., & Sciavicco, G. (2011). Two-sorted point-interval temporal logics. *Electronic Notes in Theoretical Computer Science*, 278, 31–45.
- Barker, S., & Dowe, P. (2005). Endurance is paradoxical. *Analysis*, 65(1), 69–74.
- Barwise, J., & Feferman, S. (Eds.). (1985). *Model-theoretic logics*. Berlin: Springer.
- Barwise, J., & Perry, J. (1983). *Situations and attitudes*. Cambridge, Massachusetts, USA: MIT Press.
- Baumann, R., & Herre, H. (2011, Sep 23). *The axiomatic foundation of space in GFO*. arXiv.org, <http://arxiv.org/abs/1110.5832>.
- Baumann, R., Loebe, F., & Herre, H. (2012). Ontology of time in GFO. In M. Donnelly & G. Guizzardi (Eds.), *Formal Ontology in Information Systems: Proceedings of the 7th International Conference, FOIS 2012, Graz, Austria, Jul 24-27* (pp. 293–306). Amsterdam: IOS Press.
- Becher, G., Clérin-Debart, F., & Enjalbert, P. (2000). A qualitative model for time granularity. *Computational Intelligence*, 16(2), 137–168.
- Bell, J. L. (2006). *The continuous and the infinitesimal in mathematics and philosophy*. Milano, Italy: Polimetrica.
- Benthem, J. van. (1991). *The logic of time*. Dordrecht, The Netherlands: Kluwer Academic Publishers.
- Benthem, J. van. (1995). Temporal logic. In D. M. Gabbay, C. J. Hogger, & J. A. Robinson (Eds.), *Handbook of logic in artificial intelligence and logic programming, vol. 4: Epistemic and temporal reasoning* (pp. 241–350). Oxford, UK: Clarendon Press.
- Borgo, S., & Masolo, C. (2010). Ontological foundations of DOLCE. In R. Poli, M. Healy, & A. Kameas (Eds.), *Theory and applications of ontology: Computer applications* (pp. 279–295). Heidelberg: Springer.
- Brentano, F. (1874/2008). *Psychologie vom empirischen Standpunkte*. In T. Binder & A. Chrudzinski (Eds.), *Psychologie vom empirischen Standpunkte. Von der Klassifikation der psychischen Phänomene* (pp. 1–290). Frankfurt: Ontos. (vol. 1 of Franz Brentano: Sämtliche veröffentlichte Schriften; in German)
- Brentano, F. (1925). *Versuch über die Erkenntnis*. Leipzig: Felix-Meiner Verlag. (ed. by A. Kastil; in German)
- Brentano, F. (1976). *Philosophische Untersuchungen zu Raum, Zeit und Kontinuum*. Hamburg: Felix-Meiner Verlag. (ed. by S. Körner and R. M. Chisholm; in German)
- Burek, P., Herre, H., Röder, I., Glauche, I., Scherf, N., & Löffler, M. (2010). Towards a cellular genealogical tree ontology. In H. Herre, R. Hoehndorf, J. Kelso, & S. Schulz (Eds.), *Proceedings of the 2nd Workshop of the GI-Fachgruppe "Ontologien in Biomedizin und Lebenswissenschaften" (OBML): Mannheim, Germany, Sep 9-10*. Leipzig, Germany: Institute of Medical Informatics, Statistics and Epidemiology (IMISE), University of Leipzig, Germany.
- Burke, L. (1952). On the tunnel effect. *Quarterly Journal of Experimental Psychology*, 4(3), 121–138.
- Chang, C. C., & Keisler, H. J. (1990). *Model theory* (3. ed.). Amsterdam: Elsevier.
- Cocchiarella, N. B. (1991). Formal ontology. In H. Burkhardt & B. Smith (Eds.), *Handbook of metaphysics and ontology* (pp. 640–647). Munich: Philosophia Verlag.
- Dedekind, R. (1872). *Stetigkeit und irrationale zahlen*. Braunschweig: Vieweg. (in German)
- Devlin, K. (1993). *The joy of sets: Fundamentals of contemporary set theory* (2. ed.). Berlin: Springer.
- Devlin, K. (2006). Situation theory and situation semantics. In D. M. Gabbay & J. Woods (Eds.), *Handbook of the history of logic, vol. 7: Logic and the modalities in the twentieth century* (pp. 601–664). Amsterdam: Elsevier.
- Enderton, H. B. (1993). *A mathematical introduction to logic* (12. print ed.). Boston: Academic Press.
- Fisher, M., Gabbay, D. M., & Vila, L. (Eds.). (2005). *Handbook of temporal reasoning in artificial intelligence* (Vol. 1). Amsterdam: Elsevier.
- Gabbay, D. M., & Guentner, F. (Eds.). (2002). *Handbook of philosophical logic* (2. ed., Vol. 7). Dordrecht, The Netherlands: Kluwer.
- Galton, A. (1996). Time and continuity in philosophy, mathematics, and artificial intelligence. *Kodikas/Code*, 19, 101–119.
- Galton, A. (2008). Temporal logic. In E. N. Zalta (Ed.), *The Stanford Encyclopedia of Philosophy* (Fall 2008 ed.). Stanford, California, USA: Stanford University, Center for the Study of Language and Information (CSLI).
- Grabner, J. V. (1983). Who gave you the Epsilon? Cauchy and the origins of rigorous calculus. *The American Mathematical Monthly*, 90(3), 185–194.



- Grenon, P., Smith, B., & Goldberg, L. (2004). Biodynamic ontology: Applying BFO in the biomedical domain. In D. M. Pisanelli (Ed.), *Ontologies in medicine* (pp. 20–38). Amsterdam: IOS Press.
- Grüninger, M. (2004). Ontology of the Process Specification Language. In S. Staab & R. Studer (Eds.), *Handbook on ontologies* (pp. 575–592). Berlin: Springer.
- Grüninger, M., Hahmann, T., Hashemi, A., Ong, D., & Ozgovde, A. (2012). Modular first-order ontologies via repositories. *Applied Ontology*, 7(2), 169–209.
- Grüninger, M., & Ong, D. (2011). Verification of time ontologies with points and intervals. In C. Combi, M. Leucker, & F. Wolter (Eds.), *Proceedings of the 18th International Symposium on Temporal Representation and Reasoning, TIME 2011, Lübeck, Germany, Sep 12-14* (pp. 31–38). Los Alamitos, California, USA: IEEE Computer Society.
- Hartmann, N. (1935–1950). *Ontologie*. Berlin: Walter de Gruyter. (4 Vol.)
- Haslanger, S. (2003). Persistence through time. In M. J. Loux & D. W. Zimmerman (Eds.), *The Oxford handbook of metaphysics* (pp. 315–354). Oxford: Oxford University Press.
- Hayes, P. J. (1995). *A catalog of temporal theories* (Technical Report No. UIUC-BI-AI-96-01). Urbana, Illinois, USA: University of Illinois, Beckman Institute and Departments of Philosophy and Computer Science.
- Heller, B., & Herre, H. (2004). Ontological categories in GOL. *Axiomathes*, 14(1), 57–76.
- Herre, H. (2010). General Formal Ontology (GFO): A foundational ontology for conceptual modelling. In R. Poli, M. Healy, & A. Kameas (Eds.), *Theory and applications of ontology: Computer applications* (pp. 297–345). Heidelberg: Springer.
- Herre, H. (2013). *Persistence, change and the integration of objects and processes in the framework of the General Formal Ontology*. arXiv.org, <http://arxiv.org/abs/1311.1632>.
- Herre, H., Heller, B., Burek, P., Hoehndorf, R., Loebe, F., & Michalek, H. (2007). *General Formal Ontology (GFO) – A foundational ontology integrating objects and processes [Version 1.0.1]* (Technical Report). Leipzig, Germany: University of Leipzig, Institute of Medical Informatics, Statistics, and Epidemiology (IMISE), Research Group Ontologies in Medicine (Onto-Med).
- Herre, H., & Loebe, F. (2005). A meta-ontological architecture for foundational ontologies. In R. Meersman & Z. Tari (Eds.), *On the move to meaningful internet systems 2005: CoopIS, DOA, and ODBASE: Proceedings of the OTM confederated international conferences 2005, Agia Napa, Cyprus, Oct 31 - Nov 4, 2005 (part II)* (pp. 1398–1415). Berlin: Springer.
- Hilbert, D. (1918). Axiomatisches Denken. *Mathematische Annalen*, 78, 405–415. (in German)
- Hobbs, J., & Pan, F. (2006, Sep 27). *Time ontology in OWL (W3C Working Draft)*. Cambridge, Massachusetts: World Wide Web Consortium (W3C).
- Hodges, W. (1993). *Model theory*. Cambridge, UK: Cambridge University Press.
- Huggett, N. (2010). Zeno's paradoxes. In E. N. Zalta (Ed.), *The Stanford Encyclopedia of Philosophy* (Winter 2010 ed.). Stanford, California: Stanford University, Center for the Study of Language and Information (CSLI).
- Ingarden, R. (1964). *Der Streit um die Existenz der Welt* (Vol. 1: Existenzialontologie). Tübingen, Germany: Niemeyer Verlag. (in German)
- ISO TC 184. (2004). *Industrial automation systems and integration: Process Specification Language: Part 1: Overview and basic principles* (ISO Standard No. 18629-1). Geneva, Switzerland: International Organization for Standardization (ISO).
- Jansen, L. (2001). Niko Strobach: The Moment of Change. A systematic history in the philosophy of space and time. In U. Meixner & A. Newen (Eds.), *Logical analysis and history of philosophy, vol. 4: Focus: Foundations of analytic philosophy* (pp. 205–211). Paderborn, Germany: mentis Verlag. (book review)
- Kant, I. (1787/2006). *Kritik der reinen Vernunft* (2. ed.; I. Heidemann, Ed.). Stuttgart: Reclam. (in German, (c) 1966)
- Ladkin, P. (1987). The completeness of a natural system for reasoning with time intervals. In J. P. McDermott (Ed.), *Proceedings of the 10th International Joint Conference on Artificial Intelligence, IJCAI 1987, Milan, Italy, Aug 23-28* (Vol. 1, pp. 462–467). San Francisco: Morgan Kaufmann Publishers.
- Lewis, D. (1986). *On the plurality of worlds*. Oxford: Blackwell.
- Loebe, F., & Herre, H. (2008). Formal semantics and ontologies: Towards an ontological account of formal semantics. In C. Eschenbach & M. Grüninger (Eds.), *Formal Ontology in Information Systems: Proceedings of the 5th International Conference, FOIS 2008, Saarbrücken, Germany, Oct 31-Nov 3* (Vol. 183, pp. 49–62). Amsterdam: IOS Press.
- Maiocchi, R., Pernici, B., & Barbic, F. (1992). Automatic deduction of temporal information. *ACM Transactions on Database Systems*, 17(4), 647–688.
- Masolo, C., Borgo, S., Gangemi, A., Guarino, N., & Ultramari, A. (2003). *WonderWeb Deliverable D18: Ontology library (final)* (Technical Report). Trento, Italy: Laboratory for Applied Ontology, ISTC-CNR.
- Michotte, A. (1950). A propos de la permanence phénoménale: Faits et theories. *Acta Psychologica*, 7, 298–322. (in French)
- Michotte, A. (1991). On phenomenal permanence: Facts and theories. In G. Thinés, A. Costall, & G. Butterworth (Eds.), *Michotte's experimental phenomenology of perception* (pp. 122–139). Hillsdale, New Jersey: Lawrence Erlbaum Associates. (English translation of Michotte (1950))
- Neumuth, D., Loebe, F., Herre, H., & Neumuth, T. (2011). Modeling surgical processes: A four-level translational approach. *Artificial Intelligence in Medicine*, 51(3), 147–161.
- Poli, R. (2001). The basic problem of the theory of levels of reality. *Axiomathes*, 12(3-4), 261–283.
- Rautenberg, W. (2010). *A concise introduction to mathematical logic* (3. ed.). Heidelberg: Springer.
- Reichgelt, H., & Vila, L. (2005). Temporal qualification in Artificial Intelligence. In M. Fisher, D. M. Gabbay, & L. Vila (Eds.), *Handbook of temporal reasoning in artificial intelligence* (Vol. 1, pp. 167–194). Amsterdam: Elsevier.
- Robinson, H. (2012). Dualism. In E. N. Zalta (Ed.), *The Stanford Encyclopedia of Philosophy* (Winter 2012 ed.). Stanford, California, USA: Stanford University, Center for the Study of Language and Information (CSLI).
- Shahar, Y. (1994). *A knowledge-based method for temporal abstraction of clinical data*. PhD thesis, Stanford University, Program in Medical Information Sciences.
- Sider, T. (2001). *Four dimensionalism: An ontology of persistence and time*. Oxford, UK: Clarendon Press.

- Smith, B., & Varzi, A. C. (2000). Fiat and bona fide boundaries. *Philosophy and Phenomenological Research*, *LX*(2), 401–420.
- Spear, A. D. (2006, Dec). *Ontology for the twenty first century: An introduction with recommendations* (Manual). Saarbrücken, Germany: University of Saarbrücken, Institute for Formal Ontology and Medical Information Systems (IFOMIS).
- Strobach, N. (1998). *The Moment of Change. A systematic history in the philosophy of space and time*. Dordrecht: Kluwer Academic Publishers.
- Taylor, J. G. (2010). Mind-body problem: New approaches. *Scholarpedia Journal*, *5*(10), 1580.1–4.
- Trentelman, K., Ruttenberg, A., & Smith, B. (2010). An axiomatisation of Basic Formal Ontology with projection functions. In K. Taylor, T. Meyer, & M. Orgun (Eds.), *Advances in Ontologies: Pre-Proceedings of the 6th Australasian Ontology Workshop, AOW 2010, Adelaide, Australia, Dec 7* (pp. 71–80). Pretoria, South Africa: Council for Scientific and Industrial Research (CSIR), Meraka Institute.
- Vila, L. (1994). IP: A theory of time based on instants and periods. In R. V. Rodríguez (Ed.), *ECAI 1994 Workshop on Spatial and Temporal Reasoning, Amsterdam, The Netherlands, Aug 9*.
- Vila, L. (2005). Formal theories of time and temporal incidence. In M. Fisher, D. M. Gabbay, & L. Vila (Eds.), *Handbook of temporal reasoning in artificial intelligence* (Vol. 1, pp. 1–24). Amsterdam: Elsevier.
- Vila, L., & Schwalb, E. (1996). A theory of time and temporal incidence based on instants and periods. In L. Chittaro & A. Montanari (Eds.), *Proceedings of the 3rd Workshop on Temporal Representation and Reasoning, TIME 1996, Key West, Florida, USA, May 19-20* (pp. 21–28). Washington, DC, USA: IEEE Computer Society.
- W3C. (2012). *OWL 2 Web Ontology Language Document Overview (Second Edition)* (W3C Recommendation). Cambridge, Massachusetts: World Wide Web Consortium (W3C).
- Wahlberg, T. H. (2008). Can I be an instantaneous stage and yet persist through time? *Metaphysica*, *9*(2), 235–239.
- Weidenbach, C., Dimova, D., Fietzke, A., Kumar, R., Suda, M., & Wischniewski, P. (2009). SPASS version 3.5. In R. A. Schmidt (Ed.), *Automated Deduction – CADE-22: Proceedings of the 22nd International Conference on Automated Deduction, Montreal, Canada, Aug 2-7* (pp. 140–145). Berlin: Springer.
- Wertheimer, M. (1912). Experimentelle Studien über das Sehen von Bewegung. *Zeitschrift für Psychologie*, *61*(1), 161–265. (in German)
- Wertheimer, M. (1922, January). Untersuchungen zur Lehre von der Gestalt. *Psychological Research*, *1*(1), 47–58. (in German)
- Wertheimer, M. (1923, January). Untersuchungen zur Lehre von der Gestalt II. *Psychological Research*, *4*(1), 301–350. (in German)
- Wigner, E. P. (1960). The unreasonable effectiveness of mathematics in the natural sciences. *Communications in Pure and Applied Mathematics*, *13*(1), 1–14.
- Wittgenstein, L. (1969). *Tractatus logico-philosophicus* (7. ed.). Frankfurt/Main: Suhrkamp.
- Wittgenstein, L. (1989). *Ludwig Wittgenstein und der Wiener Kreis: Werkausgabe Band 3: Gespräche, aufgezeichnet von Friedrich Waismann*. Frankfurt am Main: Suhrkamp. (in German; volume 3 of the Wittgenstein edition in 8 volumes by McGuinness, Brian F.)
- Zalta, E. N. (1983). *Abstract objects: An introduction to axiomatic metaphysics*. Dordrecht, Holland: D. Reidel Publishing Company.
- Zhang, D. (1934). *Renshi lun (epistemology)*. Shanghai: World's Book.